

PETRO VIETNAM JOURNAL



An Official Publication of the Vietnam National Oil and Gas Group Vol 10 - 2016

ISSN-0866-854X





EDITOR-IN-CHIEF

Dr. Nguyen Quoc Thap

DEPUTY EDITOR-IN-CHIEF

Dr. Le Manh Hung

Dr. Phan Ngoc Trung

EDITORIAL BOARD MEMBERS

Dr. Hoang Ngoc Dang

Dr. Nguyen Minh Dao

BSc. Vu Khanh Dong

Dr. Nguyen Anh Duc

MSc. Tran Hung Hien

MSc. Vu Van Nghiem

MSc. Le Ngoc Son

Eng. Le Hong Thai

MSc. Nguyen Van Tuan

Dr. Phan Tien Vien

MSc. Tran Quoc Viet

Dr. Nguyen Tien Vinh

Dr. Nguyen Hoang Yen

SECRETARY

MSc. Le Van Khoa

M.A. Nguyen Thi Viet Ha

DESIGNED BY

Le Hong Van

MANAGEMENT

Vietnam Petroleum Institute

CONTACT ADDRESS

Floor M2, VPI Tower, Trung Kinh street, Yen Hoa ward, Cau Giay district, Ha Noi

*Tel: (+84-4) 37727108 * Fax: (+84-4) 37727107 * Email: tapchidk@vpi.pvn.vn*

Mobile: 0982288671

Cover photo: Trai Mat, Da Lat. Photo: Le Khoa

FOCUS

Petrovietnam's oil and gas production in 2016 ESTIMATED AT OVER 27 MILLION TONS OF OIL EQUIVALENT

In the first 9 months of 2016, the Vietnam National Oil and Gas Group produced a total of 21.1 million tons of oil equivalent (13.03 million tons of crude oil and 8.07 billion m³ of gas). Petrovietnam is strictly controlling the progress of exploration, field development and production projects both at home and abroad. It is estimated that for the whole year of 2016, Petrovietnam will produce over 27 million tons of oil equivalent.



Petrovietnam's Chairman Nguyen Gian Thanh and Petrovietnam President & CEO Nguyen Huu Duong (far right) at the conference. Photo: Huu Tuyen

At the conference held on 13 October 2016, Petrovietnam's leader informed that the decline and sustained low level of oil prices had posed a lot of difficulties to the implementation of petroleum exploration and production projects, forcing the processing companies to compete with imported products while the service companies have to reduce the volume of works and service prices. However, the Group has initially implemented effective measures to cope with the low oil prices, kept up a good pace of development and over-fulfilled all its production goals for the first 9 months of 2016. Total oil and gas production reached 21.1 million tons of oil equivalent, which is an increase of 1.95 million tons (10.2%) against the 9-month plan and equal to 82.2% of the yearly plan. Of this figure, crude oil accounted for 13.03 million tons, and gas 8.07 billion m³. Besides, Petrovietnam has produced and contributed 15.82 billion kWh of electricity to the national grid, at the same time produced 1.2 million tons of urea fertilizer and 5.11 million tons of various petroleum products. By the end of September 2016, Petrovietnam has earned a total revenue of VND 327.4 trillion and contributed to the State Budget VND 64 trillion. The value of industrial production reached VND 365.5 billion, an excess of 11% of the 9-month plan and equal to 84% of the yearly plan, contributing significantly to the GDP growth of Vietnam.

Works of equitisation, divestments, and corporate restructuring have been diligently and effectively carried out by Petrovietnam in accordance with the restructuring plan approved by the Prime Minister. Their practices and waste combat are seriously deployed across the Group. All member units have implemented the Action Programme for expenditure reduction and lower production costs. As a result, in 9 months of 2016, the Group has cut costs by VND 7,488 trillion, equal to 82.7% of the yearly plan.

Petrovietnam leaders highly appreciated that all member units had implemented effective measures to cope with the context of declining oil prices. In particular, Petrovietnam leaders appreciated Vietsoviet Joint Venture and the Petrovietnam

4 PETROVIETNAM JOURNAL VOL.10/2016

FOCUS



ORIENTATIONS OF OIL AND GAS EXPLORATION IN 2017 - 2020

At the workshop 'Oil and gas potential and exploration plan for 2017, orientations to 2020' in Ba Ria - Vung Tau province, the Vietnam Oil and Gas Group organised the workshop 'Oil and gas potential and exploration plan for 2017, orientations to 2020' in Ba Ria - Vung Tau province. The workshop focused on discussing the following issues: planning for exploration and appraisal in the northern part of Song Hong basin; orientation for exploration activities in the southern part of Song Hong basin and Phu Khanh basin; evaluating the remaining oil and gas potential of Block 09-1 after the 3D/4C

8 PETROVIETNAM JOURNAL VOL.10/2016

SCIENTIFIC RESEARCH



PETROLEUM EXPLORATION & PRODUCTION

- 14.** Pliocene - Pleistocene sequence stratigraphy in Block 05-2, Nam Con Son basin, offshore Vietnam
- 20.** Optimal well placement techniques in low contrast clastic reservoirs utilising integrated technologies and real-time data to minimise uncertainty in challenging low contrast clastic reservoirs
- 24.** Some solutions to improve the cement bond quality for carbonate zones in Block 05-1a, offshore Vietnam
- 32.** Reservoir model and application of seismic attributes to predict Lower Miocene B10 sandstone reservoir distribution in Su Tu Den oil field, Block 15-1, Cuu Long basin
- 38.** Interwell tracer method using partitioning compounds naturally existing in crude oil for determination of residual oil saturation



PETROLEUM PROCESSING

- 44.** Simple method to fabricate superhydrophobic carbon steel surface
- 48.** Carbonyl sulfide presence in syngas stream produced from biomass gasification processes: measurement and calculation



PETROLEUM SAFETY & ENVIRONMENT

- 54.** Climate change reality and implications for the oil and gas industry

PETROLEUM EXPLORATION & PRODUCTION

PLIOCENE - PLEISTOCENE SEQUENCE STRATIGRAPHY IN BLOCK 05-2, NAM CON SON BASIN, OFFSHORE VIETNAM

Phung Van Phung*, Nguyen Thanh Tung*, Khuu Hong Giang*, Nguyen Xuan Phong*
 *Vietnam Petroleum Institute
 *Sino-Geep Petroleum Operating Company
 Petrovietnam Exploration-Production Corporation
 Email: phungv@pvi.vn

Summary

Sequence-stratigraphic investigation using high-resolution 3D seismic data allows recognition of the detailed stratigraphic features of the Pliocene and Pleistocene succession such as incised valleys or channels and basin floor fans. They are excellent evidences for recognition of the backward system tract. Integration of seismic attributes and well data was used to predict their distributions as well as lithofacies. This article concentrates on sequence stratigraphy interpretation of seismic and well log data for prediction of the depositional environments of each sequence.

Key words: Channel and basin floor fan, depositional environment, seismic attribute.

1. Introduction

Block 05-2 is located in Nam Con Son basin, a rift basin in Vietnam, near the Mekong River system. The river system plays a significant role in transporting sediments into the basin, as the study area is about 200km from the current shoreline of Vietnam (Figure 1). The general stratigraphy and structure were recorded as the pre-rift stage during Eocene to Early Oligocene, the first syn-rift stage from late Early Oligocene to late Oligocene, the subsidence stage during Early Miocene, the second syn-rift stage up to Middle Miocene and the post-rift from Upper Miocene to recent time [1].

Eight sequence boundaries namely S1, S2, S3, S4, S5, S6, S7 and S8 were interpreted based on the terminal seismic reflections such as downlap, onlap and truncation features as well as surfaces associated with incised valleys (IV) and/or canyon margins (Figure 2). By integration of seismic data and well log data, the system tracts within each sequence were defined to understand the detailed depositional processes.

Incised valleys and basin floor fan deposits are controlled by variations of relative sea level, sediment input, tectonics and internal channel cuts or their development mechanisms.

This paper focuses on the following objectives:

- Interpret 3D seismic patterns integrated with well data in order to understand the depositional processes.
- Define the system tracts of each sequence from Pliocene to recent time.

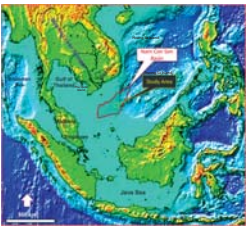

Figure 1. The study area (100km square) is located in Nam Con Son basin.

14 **PETROLEUM JOURNAL**, VOL. 10 (2016)

FOCUS

Petrovietnam’s oil and gas production in 2016 estimated at over 27 million tons of oil equivalent **4**

Orientations of oil and gas exploration in 2017 - 2020 **8**

Petrovietnam attends the 34th ASEAN Ministers on Energy Meeting (AMEM) **10**

BSR has efficiently refined 47 million tons of crude oil **12**

NEWS

Vietnam, Russia seek to facilitate oil and gas co-operation **72**

Contract signed for Dai Hung gas processing services on Thien Ung platform **73**

Aluminum sacrificial anode proposed for addition to the list of indigenous products **74**

PVFCo awarded "50 best listed companies in Vietnam" prize **75**



PETROLEUM ECONOMICS & MANAGEMENT

64. An overview of Vietnam’s oil and gas industry

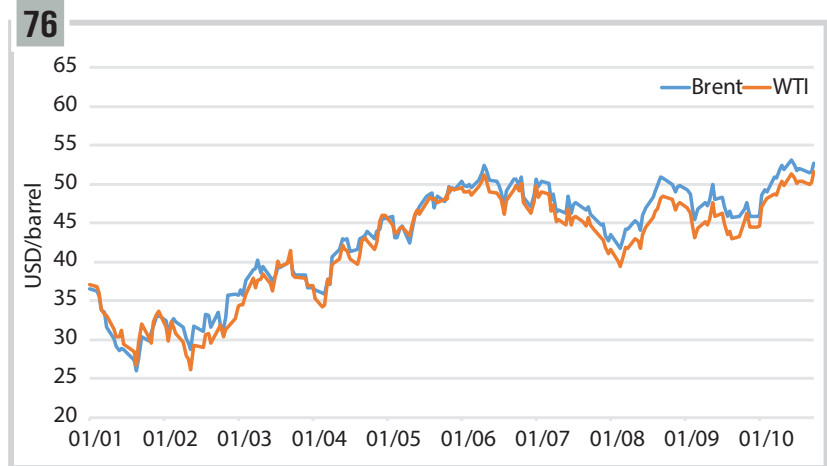
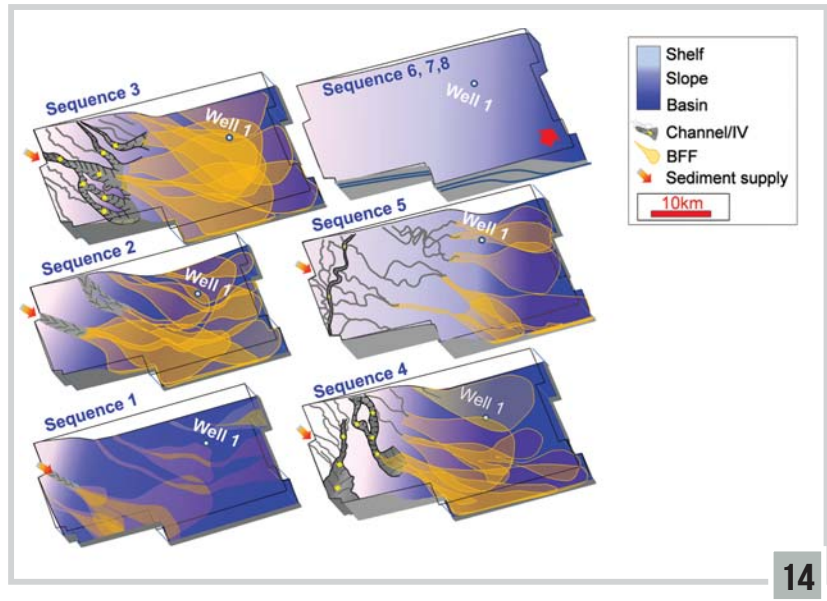

Petrovietnam's oil and gas production in 2016 ESTIMATED AT OVER 27 MILLION TONS OF OIL EQUIVALENT

In the first 9 months of 2016, the Vietnam National Oil and Gas Group produced a total of 21.1 million tons of oil equivalent (13.03 million tons of crude oil and 8.07 billion m³ of gas). Petrovietnam is strictly controlling the progress of exploration, field development and production projects both at home and abroad. It is estimated that for the whole year of 2016, Petrovietnam will produce over 27 million tons of oil equivalent.

At the conference held on 13 October 2016, Petrovietnam's leader informed that the decline and sustained low level of oil prices had posed a lot of difficulties to the implementation of petroleum exploration and production projects, forcing the processing companies to compete with imported products while the service companies have to reduce the volume of works and service prices. However, the Group has initially implemented effective measures to cope with the low oil prices, kept up a good pace of development and over-fulfilled all its production goals for the first 9 months of 2016. Total oil and gas production reached 21.1 million tons of oil equivalent, which is an increase of 1.95 million tons (10.2%)



Petrovietnam's Chairman Nguyen Quoc Khanh and Petrovietnam's President & CEO Nguyen Vu Trung Son chaired the conference. Photo: Nhu Trang

against the 9-month plan and equal to 82.3% of the yearly plan. Of this figure, crude oil accounted for 13.03 million tons, and gas 8.07 billion m³. Besides, Petrovietnam has produced and contributed 15.82 billion kWh of electricity to the national grid, at the same time produced 1.2 million tons of urea fertilizer and 5.11 million tons of various petroleum products. By the end of September 2016, Petrovietnam has earned a total revenue of VND 327.4 trillion and contributed to the State Budget VND 64 trillion. The value of industrial production reached VND 369.5 trillion, an excess of 11% of the 9-month plan and equal to 84% of the yearly plan, contributing significantly to the GDP growth of Vietnam.

Works of equitisation, divest-

ments, and corporate restructuring have been stringently and effectively carried out by Petrovietnam in accordance with the restructuring plan approved by the Prime Minister. Thrift practice and waste combat are seriously deployed across the Group. All member units have implemented the Action Programme for expenditure reduction and lower production costs. As a result, in 9 months of 2016, the Group has cut costs by VND 7.486 trillion, equal to 82.7% of the yearly plan.

Petrovietnam leaders highly appreciated that all member units had implemented effective measures to cope with the context of declining oil prices. In particular, Petrovietnam leaders appreciated Vietsovpetro Joint Venture and the Petrovietnam



Load-out of BK-Thien Ung platform topside. Photo: Duc Hau

Average crude oil price in the first 9 months of 2016 dropped by 25% as compared with the same period of 2015, and only amounted to USD 42.7/barrel, which is equal to 71.2% of the projected price (USD 60/barrel). The Petrovietnam's financial targets though lower than planned but are much more positive compared to the decline of oil prices. Especially, its 9-month industrial production value is 11% higher than the plan while domestic crude oil production records an excess of 8.1% over the 9-month targets, equivalent to an increase of 858,000 tons, thus significantly contributing to the nation's 5.93% GDP growth in the first 9 months of 2016.

No.	Content	Unit	Goal set by Government for 2016	Goal for 4 th quarter of 2016	Forecasted achievements in 2016
1	Oil and gas production	Million tons of oil equivalent	25.64	6.49	27.31
	Oil	Million tons	16.03	3.88	17.01
	- in Vietnam	Million tons	14.02	3.38	15.02
	- Abroad	Million tons	2.01	0.50	1.99
	Gas	Billion m ³	9.61	2.61	10.30
2	Electricity	Billion kWh	20.27	5.80	21.56
3	Urea	Million tons	1.582	0.417	1.621
4	Petroleum products	Million tons	5.690	1.469	6.577

Exploration Production Corporation (PVEP) had reviewed costs to ensure financial balances to complete the yearly oil production plan. The investment solutions of Vietsovpetro have brought high efficiency, putting the RC-9 structure into operation 1 month and 9 days earlier than planned.

The conference discussed and proposed solutions to overcome

difficulties and ensure the progress of implementation of major oil and gas projects: Block B, Ca Voi Xanh, and Ca Rong Do field development projects, Nghi Son Refinery and Petrochemical Complex, Dung Quat Refinery Expansion and Upgrading project, and the thermal power projects.

Regarding the key tasks in the 4th quarter of 2016, Petrovietnam



will continue to strictly control the progress of exploration, field development and production projects both at home and abroad, sign 1-2 new oil and gas contracts and bring 2 oil and gas fields/structures into operation. The Group plans to further produce 6.49 million tons of oil equivalent (3.88 million tons of crude oil and 2.61 billion m³ of gas) in the remaining months of this year. The conference has set out specific measures for each sector.

In the area of exploration and production, the Group continues to select and deploy drilling of exploration/appraisal wells which are highly feasible in order to ensure oil and gas reserve increase in 2016 at the highest level possible. Factors affecting oil and gas production will be reviewed for timely response measures, field development activities to be intensified, Su Tu Trang field - phase 1 (Block 15-1), and Thien Ung field to be put into production.

Production in the blocks/fields with good production costs will be aligned with the targets of increasing domestic oil production by 1 million tons against the Government's yearly plan of 2016, and efforts continue to be made to review and cut costs in order to reduce oil and gas production costs.

For the gas sector, the Group will ensure the stable and safe operation of gas transportation systems and gas processing plants (Nam Con



Bach Ho field. Photo: Minh Tri

Son and Dinh Co) to improve the efficiency of gas production and processing, and closely co-ordinate with the consumers to ensure maximum consumption of gas produced.

In the field of power generation, the Group will ensure the safe operation of power plants, closely collaborate with Vietnam Electricity (EVN) to mobilise the maximum capacity of the power plants, and ensure the progress of power projects.

For the petroleum processing sector, the Group will ensure the stable and safe operation of Dung Quat Refinery, Ca Mau Fertilizer Plant and Phu My Fertilizer Plant. It will leverage the favourable impact of lower prices for oil (which is the raw material and fuel of the plants) to maximise the operational efficiency of the units. The product structure will be optimised from time to time in response to fluctuations of oil prices and the market to ensure business efficiency.

In the area of petroleum services, the Group continues to direct and support its units to accelerate the restructuring of enterprises to increase operational efficiency and ensure the rights of shareholders; closely collaborate with petroleum exploration and production units to implement the tasks and targets assigned; and explore to expand the domestic and foreign markets in order to ensure sustainable development.

In the coming period, Petrovietnam will continue to implement the Strategy for development until 2025 and orientations to 2035, focus on completing the Petrovietnam restructuring plan for the 2016 - 2020 period and submit it for the Prime Minister's approval. In particular, the key tasks will be to enhance production and business efficiency and competitiveness in the context of declined oil prices.

Under the yearly plan set by the Government for 2016, Petrovietnam will produce 25.64 million tons of oil equivalent (16.03 million tons of crude oil and 9.61 billion m³ of gas); 20.27 billion kWh of electricity, 1.582 million tons of urea, and 5.690 million tons of petroleum products. Petrovietnam's Chairman Nguyen Quoc Khanh and Petrovietnam's President & CEO Nguyen Vu Truong Son emphasised the determination to mobilise all resources to complete ahead of schedule the key tasks of 2016, focusing on enterprise restructuring, research and application of scientific and technological achievements, investment in new technologies to improve production and business efficiency, and contributing to the assurance of the national energy security.

Ngoc Phuong



ORIENTATIONS

OF OIL AND GAS EXPLORATION IN 2017 - 2020

At the workshop "Oil and gas potential and exploration plan for 2017, orientations to 2020", the Vietnam Oil and Gas Group reviewed the plan for oil and gas exploration and the measures to ensure the goal of increasing oil and gas reserves in the 2017 - 2020 period. Petrovietnam is expected to drill 8 - 10 exploration/appraisal wells in Vietnam, and increase reserves by 10 - 15 million tons of oil equivalent in 2017.

On 7 October 2016, the Vietnam Oil and Gas Group organised the workshop "Oil and gas potential and exploration plan for 2017, orientations to 2020" in Ba Ria - Vung Tau province. The workshop focused on discussing the following issues: planning for exploration and appraisal in the northern part of Song Hong basin; orientation for exploration activities in the southern part of Song Hong basin and Phu Khanh basin; evaluating the remaining oil and gas potential of Block 09-1 after the 3D/4C



Cuu Long basin. Photo: Minh Tri

seismic survey and the exploration plan for the 2017 - 2020 period; the exploration and appraisal objects in Cuu Long basin's blocks operated by PVEP POC, the exploration plans for 2017 and orientations to 2020; the undeveloped discoveries and the remaining oil and gas potential of Blocks 01 and 02; evaluating the remaining oil and gas potential of the blocks operated by Vietsovpetro Joint Venture (except for Block 09-1), the exploration plans for 2017 and

orientations to 2020; the remaining potential of Block 15-1, the tertiary exploration plan for 2017 and the following years; and proposing Petrovietnam's exploration plans for 2017 and orientations to 2020.

As of September 2016, Petrovietnam has completed 850km² of 3D seismic acquisition, finished the construction of 5 exploration wells and 2 appraisal wells, increased reserves to 8 million tons of oil equivalent, and made an oil and gas discovery,

which is Phong Lan Dai - 1X (Block 06-1). In 2017, Petrovietnam plans to drill 8-10 exploration/appraisal wells in Vietnam, and increase reserves by 10 - 15 million tons of oil equivalent.

Based on the opinions and comments at the workshop, Petrovietnam Vice President Nguyen Quynh Lam requested the Petroleum Exploration Division to study and organise thematic workshops for each basin/area in order to solve the main issues in each exploration phase. The Petrovietnam subsidiaries consider the possibility of sole risk drilling for exploration objects in the development area, for contracts of production development (in case operators do not conduct tertiary exploration/appraisal drilling).

For the new discoveries which cannot be developed at present, Petrovietnam leaders requested detailed assessments to be made and researches conducted on their development plan on the basis of tie-in with adjacent operating fields. In addition, it is necessary to evaluate the results after drilling at each block/area, make appraisal plans with the optimal number of wells, and research for application of new technologies and reduction of drilling costs.

For Song Hong basin, Petrovietnam required PVEP to re-plan/research and propose the overall development plan in order to put discoveries into production, reduce the drilling costs (research "slim hole" technology), optimise designs and apply new technologies.

For Cuu Long basin, Petrovietnam requested its subsidiaries to focus on in-depth research and detailed assessment to ensure not missing exploration objects, particularly in the areas with available infrastructure, and research to assess the potential of objects from Miocene, Oligocene and basement.

Ngoc Minh

PETROVIETNAM ATTENDS the 34th ASEAN Ministers on Energy Meeting



Petrovietnam's delegation attend the 34th ASEAN Ministers on Energy Meeting. Photo: PVN

With the theme "Towards Greener Community with Cleaner Energy", the 34th ASEAN Ministers on Energy Meeting (AMEM) focused on discussing the goals and strategic measures to improve energy efficiency and raise awareness about clean energy sources, in line with the ASEAN Plan of Action on Energy Co-operation (APAEC) in 2016 - 2020. The meeting has agreed on the target of increasing the component of renewable energy in the ASEAN energy mix to 23% by 2025.

The 34th ASEAN Ministers on Energy Meeting (AMEM) was held from 21 to 23 September 2016 in Nay Pyi Taw, the capital of Myanmar under the theme "Towards Greener Community with Cleaner Energy". The 13th ASEAN +3 Ministers on Energy Meeting (AMEM +3), the 10th East Asia Summit Energy Ministers Meeting (EAS EMM) and the 5th Dialogue between the ASEAN Ministers on Energy and the International Energy Agency (IEA) were also held back-to-back with the 34th AMEM.

At the meeting, Mr. Cao Quoc Hung, Vietnam's Deputy Minister of Industry and Trade, delivered a presentation highlighting

some issues which are currently of concern to Vietnam for future energy development, including: (i) advocating ASEAN gas pipeline connectivity and ASEAN electricity network connectivity for strengthening the regional energy security, supporting each other and ensuring energy supply for ASEAN countries; (ii) promoting development of new energies and renewable energies in Vietnam and ASEAN towards a green and clean environment for ASEAN; (iii) further completing the legal basis for encouraging and strengthening scientific and technological applications for efficient and economical use of energy resources; (iv) the current situation and the



Dr. Phan Ngoc Trung, Member of Petrovietnam's Board of Directors, visited PVDrilling Myanmar Office. Photo: PVN



Petrovietnam delegation visited and encouraged the staff of PVEP Overseas. Photo: PVN

need to continue developing high-tech coal-fired power plants, meeting the environmental protection requirements in Vietnam.

Myanmar's Electricity and Energy Deputy Minister Tun Naing said that the 34th AMEM had reached an agreement on enhancing connectivity for energy security and accessibility through the construction of additional natural

gas pipeline, the promotion of clean coal technologies and civilian nuclear energy in 2016 - 2017. The ASEAN Ministers on Energy decided to convene the 35th AMEM in the Philippines in 2017.

During the 34th AMEM, Dr. Phan Ngoc Trung, Member of the Board of Directors of the Vietnam Oil and Gas Group (Petrovietnam), together with the Leader of the Ministry of

Industry and Trade had a meeting and discussions with the US - ASEAN Business Council (US - ABC) and the US Deputy Assistant Secretary of Energy, Mr. Alan Yu, with the aim to strengthen the comprehensive co-operation between the US and the ASEAN countries in general and Vietnam in particular. US businesses recommended some areas for co-operation with Vietnam, including exploitation of minerals and petroleum with such groups as Rio Tinto, ConocoPhillips and GE, which was the area where the business partners are looking for potential opportunities for development in Vietnam in the coming period.

On the sidelines of the event, Dr. Phan Ngoc Trung and the Petrovietnam delegation had a meeting with Mr. Tun Naing, Myanmar's Electricity and Energy Deputy Minister, Mr. U Myo Myint Oo, Managing Director of Myanmar Oil and Gas Enterprise (MOGE), and Mr. Suy Sem, Cambodian Minister of Mines and Energy, with regard to co-operation and support for activities of PVEP Overseas, PVD Myanmar and PV OIL in Myanmar and Cambodia.

On the occasion of their business trip to Myanmar, the Petrovietnam delegation visited and encouraged the staff of PVEP Overseas' and PV Drilling's representative offices who are implementing the projects in Myanmar. The Petrovietnam's leader required all the units to regularly co-ordinate and support each other in work as well as to build good relationships with the local governments in the partner country to facilitate the implementation of the projects in Myanmar.

Tien Dat - Thu Huyen



Importing crude oil via single point mooring. Photo: BSR

BSR HAS EFFICIENTLY REFINED 47 million tons of crude oil

Binh Son Refining and Petrochemical Company Limited (BSR) announced it had successfully imported the 600th oil shipment for Dung Quat Refinery via the single point mooring (SPM) with a total volume of nearly 47 million tons.

Since receiving the first shipment of oil from the Torn Gudrun vessel (29 December 2008) to date, BSR has imported nearly 47 million tons of crude oil via the single point mooring (SPM), processed and sold about 42 million tons of petroleum products. Nowadays, the SPM can handle vessels of up to 150,000DWT. It means that BSR can receive crude oil from many different parts of the world including West Africa, the Mediterranean, and the Middle East, etc. This not only helps reduce the transportation costs but also diversifies the import sources

of low price crude oil. The successful import of 600 crude oil shipments has facilitated the continuous, safe and stable operation of Dung Quat Refinery at 105% of its designed capacity.

The structure of crude oil supplies to Dung Quat Refinery is now experiencing a shift towards gradually reducing Bach Ho sweet oil and increasing crude oil from other fields such as Te Giac Trang and Dai Hung. At the same time, BSR also imports many sour oil shipments from other countries to mix with the domestic light sweet oil in order to



Dung Quat Refinery. Photo: BSR

save production costs and increase profits for the company.

In recent years, BSR has focused on optimising production operation; promoting scientific research, with primary emphasis on energy savings, optimising operational conditions of the technological processes to reduce production costs, and improve production and business efficiency. The company has studied and selected the types of crude oil which are compatible with the technological configuration of Dung Quat Refinery; and increased the ratio of crude oil to be mixed with Bach Ho crude to ensure adequate supply of raw materials and increase profits for the plant. With the aim of enhancing capacity, increasing flexibility in the processing of crude

oil, and upgrading technology to ensure the production of high-quality petroleum products and enhance competitiveness, BSR is implementing the project to upgrade and expand Dung Quat Refinery to bring its capacity from the current 6.5 million tons per year to 8.5 million tons per year.

Dung Quat Refinery upgrading and expansion project has been implemented for 17 months out of its 78 months. The front end engineering design contract (FEED) has deployed approximately 43.9% of the workload. BSR has also signed 7 contracts for technological copyright for the workshops: HGU, DHDT, GHDT, SDA, ALKYL, NHT, and SRU; and is currently implementing the basic engineering design

package (BEDP). This project helps BSR solve 3 problems: meeting Euro IV and V environmental standards; pro-actively ensuring crude oil input sources (with 80% of domestic oil and 20% of imported oil), and being able to process 75 types of crude oil; thus improving the economic efficiency.

In the first 9 months of 2016, BSR has produced nearly 5.1 million tons of products, which is equal to 88% of the yearly plan; earned a total revenue of VND 51.886 trillion, equivalent to 63% of the yearly plan; and contributed to the State Budget an estimated amount of VND 8.625 trillion, equal to 72% of the yearly plan.

Hong Minh

PLIOCENE - PLEISTOCENE SEQUENCE STRATIGRAPHY IN BLOCK 05-2, NAM CON SON BASIN, OFFSHORE VIETNAM

Phung Van Phong¹, Nguyen Thanh Tung¹

Khuc Hong Giang², Nguyen Xuan Phong³

¹Vietnam Petroleum Institute

²Bien Dong Petroleum Operating Company

³Petrovietnam Exploration Production Corporation

Email: phongpv@vpi.pvn.vn

Summary

Sequence-stratigraphic investigation using high-resolution 3D seismic data allows recognition of the detailed stratigraphic features of the Pliocene and Pleistocene succession such as incised valleys or channels and basin floor fans. They are excellent evidences for recognition of the lowstand system tract. Integration of seismic attributes and well data was used to predict their distributions as well as lithofacies. This article concentrates on sequence stratigraphy interpretation of seismic and well log data for prediction of the depositional environments of each sequence.

Key words: Channel and basin floor fan, depositional environment, seismic attribute.

1. Introduction

Block 05-2 is located in Nam Con Son basin, a rift basin in Vietnam, near the Mekong River system. The river system plays a significant role in transporting sediments into the basin, as the study area is about 260km from the current shoreline of Vietnam (Figure 1). The general stratigraphy and structure were recorded as the pre-rift stage during Eocene to Early Oligocene, the first syn-rift stage from late Early Oligocene to Late Oligocene, the subsidence stage during Early Miocene; the second syn-rift stage up to Middle Miocene and the post-rift from Upper Miocene to recent time [1].

Eight sequence boundaries namely S1, S2, S3, S4, S5, S6, S7 and S8 were interpreted based on the terminal seismic reflections such as downlap, onlap and truncation features as well as surfaces associated with incised valleys (IV) and/or canyon imbricates (Figure 2). By integration of seismic data and well log data, the system tracts within each sequence were defined to understand the detailed depositional processes.

Incised valleys and basin floor fan deposits are controlled by variations of

relative sea level, sediment input, tectonics and internal channel cuts or their development mechanisms.

This paper focuses on the following objectives:

- Interpret 3D seismic patterns integrated with well data in order to understand the depositional processes.
- Define the system tracts of each sequence from Pliocene to recent time.

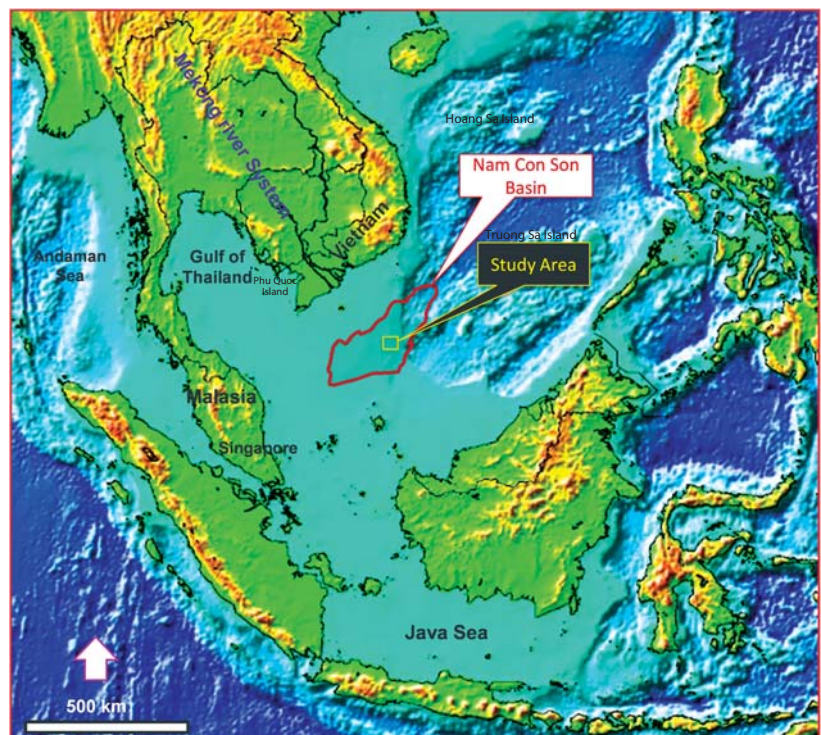

Figure 1. The study area (Yellow square) is located in Nam Con Son basin

- Correlate the variations in relative sea level, sediment supply and subsidence rate to the depositional processes in the area.
- Understand the evolutions of these channel cuts/incised valleys and basin floor fans deposits and their relationships within each sequence.
- Construct the Gross Depositional Environment (GDE) map for each sequence.

2. Database and methodology

The datasets used in this study include high-resolution 3D seismic data, one well with main log curves such as GR, DT, LLS, LLD and the check-shot data. The 3D seismic data, which cover an area of approx. 1,000km², are of very good quality with high resolution, inline and crossline spacing of 12.5 x 12.5m. The dominant frequencies are from 40Hz to 60Hz. The seismic attributes including amplitude, and incoherence, combining with root mean square (RMS) amplitude were used to interpret and predict distributions of channel cuts or incised valleys and basin floor fans.

The main works of sequence stratigraphic study focused on seismic sequence stratigraphy and well log analysis. For seismic sequence stratigraphic analysis, it was accomplished in several steps, such as determination of seismic sequence stratigraphic unit - recognition and picking; interpretation of sedimentary processes based on seismic patterns; and understanding of external processes that affect stratigraphy.

- Determination of seismic sequence stratigraphic unit - recognition and picking:

Eight sequence stratigraphic units were interpreted by recognition of sequence boundaries. A sequence boundary was picked by truncation, onlap, downlap or concordance as well as internal and external geometries. They were mapped and labelled as S1, S2, S3, S4, S5, S6, S7, S8 (S-Surface) and SB (Seabed) (Figure 2).

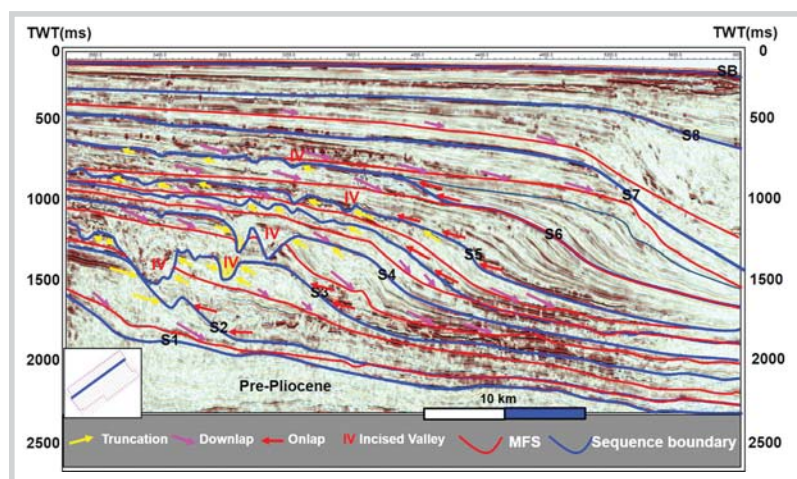

Figure 2. Seismic reflections terminations are used to define sequence boundaries and to illustrate incised valley (IV) as well as basin floor fan

- Interpretation of sedimentary processes based on seismic patterns:

Seismic parameters within each seismic unit framework, including reflection configurations, amplitude, continuity and frequency, were analysed to understand the sedimentary processes. These parameters can be used to interpret the lithology, bedding spacing, fluid contents, contacts and depositional environments, and the paleo-topography. Figures 2 and 3 show reflection terminations and seismic facies.

- Understanding of external processes that affect stratigraphy in the area:

Sediment supply, relative sea level and subsidence rate were discussed in order to understand the external processes, which influenced the basin architecture.

Sediment supply depended on both the fluvial drainage and the mechanical erosion [2] and is one of the fundamental variables that determine the type of depositional trend in all fluvial to marine environments [3].

Based on log curves such as GR, DT and Resistivity, the transgressive surface (TS), flooding surfaces (FS), and maximum flooding surfaces (MFS) could be recognised. The maximum flooding surface is defined as a surface between the fining upward of the TST and the coarsening upward of the HST. The transgressive surface is interpreted by a surface between the coarsening upward of the LST and the fining upward of the TST (Figure 5). Commonly, some system tracts cannot be seen on seismic data at the well location even with very high resolution as the current seismic data; however, they could be defined on well log curves because of the higher resolutions of well log data.

There are three basic controls to a sequence developed: subsidence rate; sediment supply rate; and eustatic sea level change.

The rates of the subsidence are determined by two primary factors:

tectonics and sedimentary loading. However, in this case, the rates of the tectonic subsidence have not played an important role to total subsidence rates of the basin because it has been stable during Pliocene to recent time (the post-rift stage of the basin). Therefore, only the rates of sedimentary loading subsidence have been discussed, considered and interpreted through sequences based on observation of seismic lines through internal - external seismic features and isopach maps.

The sediment supply rate in any location can significantly vary through time and there will be large lateral variations within a basin. It depends on both the source to basin relief, which in general terms is dictated by tectonics as well as by the climate. Climate also controls the nature of the sedimentary fill of a basin. Differences in lithology can lead to significant differential compaction and sedimentary processes during deposition [4].

Eustatic sea level and subsidence interact to produce or remove space in which the sediment supplied into the basin can accumulate. This space is called accommodation. A curve describing the variation of total accommodation through time in a basin can, therefore, be constructed by adding successive incremental changes in eustasy to the cumulative subsidence curve. This curve is, in consequence, the same as the relative sea level curve. Therefore, the relative sea level curve plays an extremely important role in order to understand not only the development of sequences but also their components [4].

3. Results and discussions

Generally, the sedimentary subsidence rate could vary from margin to slope and down to basin-ward. In fact, the sedimentary loading subsidence is not exactly the same at margin, slope or basin position. However, this study area is too small to compare with the whole basin. Therefore, it is assumed that the sedimentary loading subsidence rates in the study area are uniform. Vertical changes in stacking patterns and internal seismic

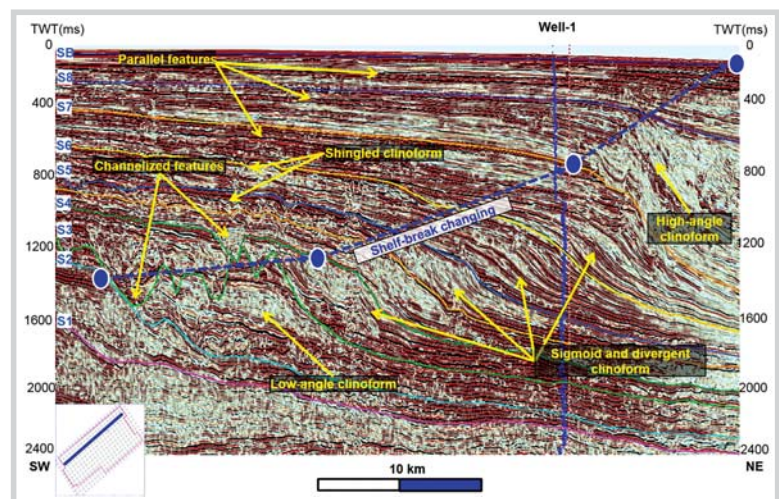

Figure 3. Demonstrations of seismic facies through sequence to sequence. The blue line has meaning of shelf break variation due to changing of subsidence rates

geometries along the margin of the basin represent temporal variations in subsidence rate. Through sequences 1 - 4, a lot of incised valleys/channel cuts were observed across the shelf, which might support low subsidence rate during these intervals. More progradational developments at the slopes, aggradation configurations along the shelf during sequences 5 and 6 suggest the rate of subsidence was higher these times. The youngest sequences 7 and 8 are characterised by thick developed aggradations/progradations to the basin. These mean that high sediment supply was controlled during these times (Figures 2 and 3).

In terms of the higher sediment flux, the larger the volume of sediment entering the basin, the thicker the resultant succession will be. Based on Figure 2, the thickness of upper sequences S6, S7 and S8 reflects the periods of high sediment supply in the study area. Conversely, the lower the sediment flux, the thinner the resulting succession will be as the sections of sequences S1 to S5 showing the periods of the low sediment supplied.

Normally, when relative sea level falls below the shelf edge, the sediments of the lowstand systems were deposited. However, when relative sea level is above the former shelf edge, the sediments of the highstand were built. The third division of strata of a sequence were known as the transgressive deposits when relative sea level initially floods the former shelf. During this time, the shoreline moves landwards, although this may be in a step-wise fashion being interrupted by periods of basin-ward progradation (Figure 4). In this study area, a relative sea level curve has not been constructed because of lacks of data and tools. Therefore, the published relative sea level curve of Wornardt et al [5] completed by observations of the stratigraphic unit in the Gulf of Mexico was used to understand how to match the sequence boundaries with the relative sea level change. It is clear that sequence S3 has a good tie with 3.21Ma of relative sea level. Another sequence (S4) is the second good candidate for

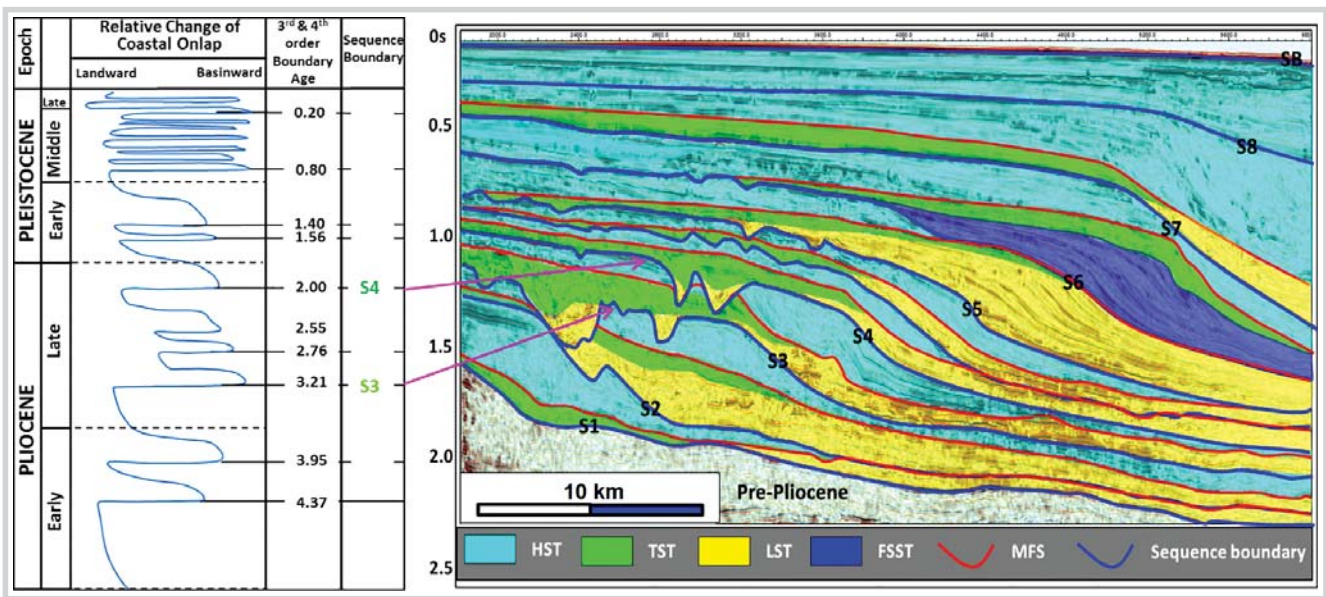

Figure 4. The correlation of the relative sea level change with sequence boundaries: S3, S4 and system tract definitions are interpreted on seismic section

matching with 2.00Ma of the relative sea level (Figure 4).

Based on seismic sections and seismic attributes, canyon systems/channels/incised valleys and basin floor fans (BFF) features can be interpreted. They can be seen clearly from sequence 1 to sequence 6, and it is quite difficult to identify channels in upper sequences, such as in sequences 7 and 8, due to their thickness below seismic resolution or channels may lie outside the seismic survey area.

For sequences 1 and 2, almost all sediments were deposited at slope and basin positions. This means channel features are associated with basin floor fans, both long and short drift fans, due to variation of flow energy.

In sequences 3, 4, 5 and 6, the channel/canyon/incised valleys develop strongly. They can reflect extreme relative sea level change during this interval. In addition, basin floor fans can be created after channels bring products of erosion basin-ward. They develop through time with multiple stages and overlap together. Both long and short drift path basin floor fans can be seen in these intervals, which were controlled by different energy of channels of each stage of evolution. Therefore, grain sizes of sediments of basin floor fans can vary from fine (mud) to coarse (sand) grain as GR signature.

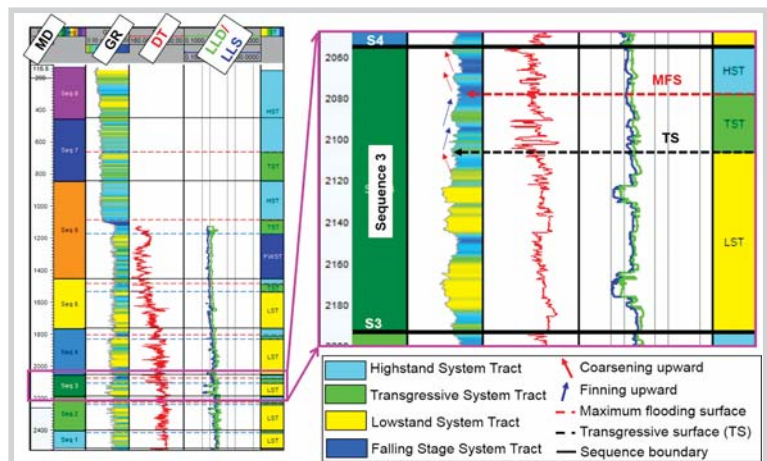

Figure 5. System tract on well log is defined when combining with sequence boundaries from seismic. Within Sequence 3, the LST contributes by floor fans with sharp blocky characteristic of GR log, the TS reflects by finning upward trend and the HST was undertaken by coarsening upward trend

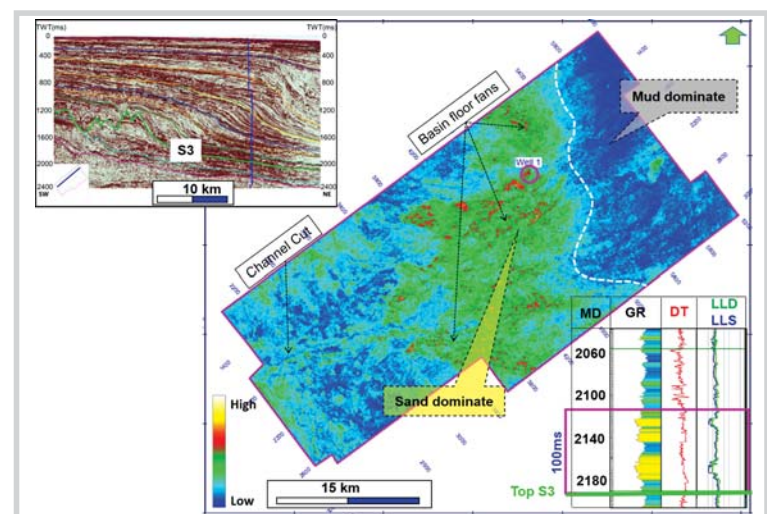

Figure 6. A root mean square attribute map of 100ms window above S3 surface shows channel and basin floor fan distribution and lithology of basin floor fans

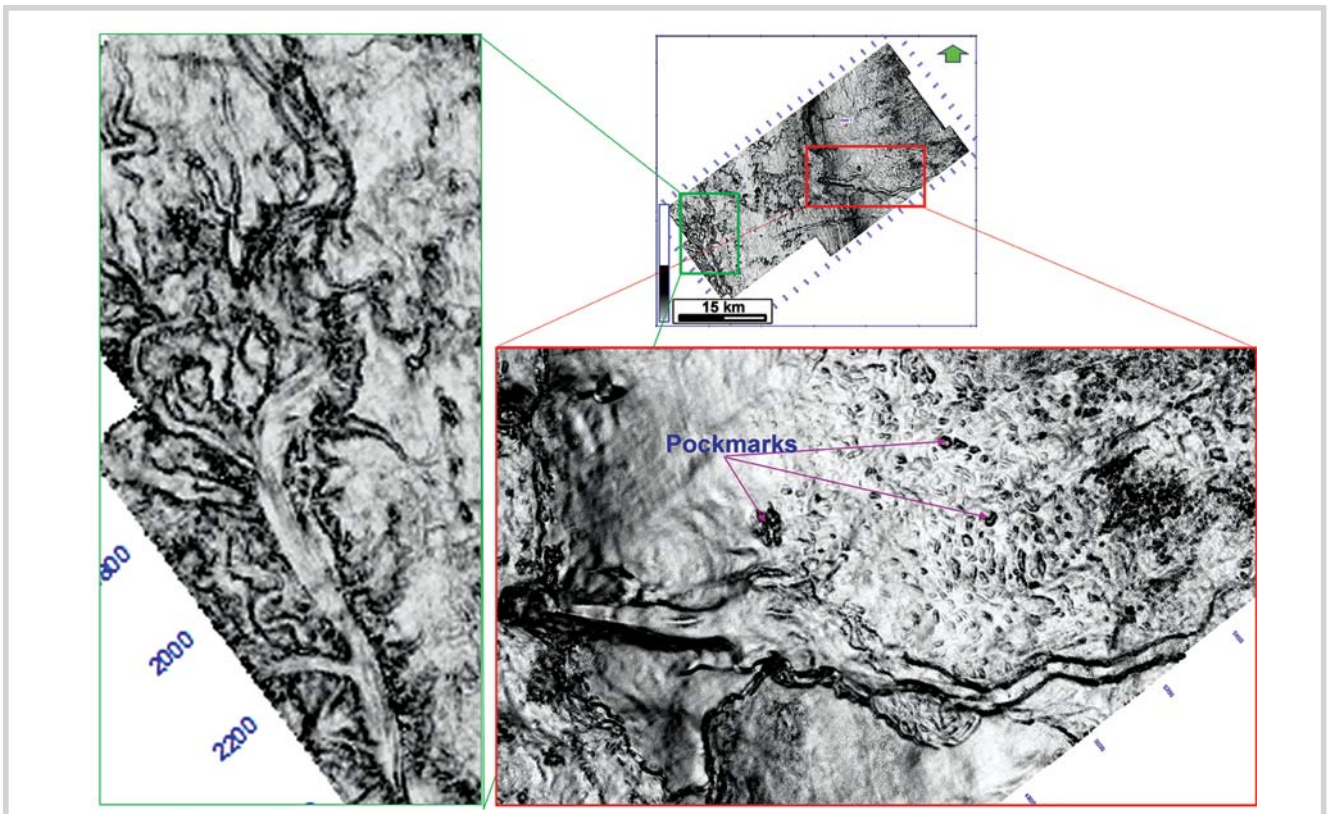

Figure 7. A root mean square attribute map of 30ms window above S5 surface showing the architectures of channels and basin floor fans; dark point could be gas pockmarks, channel migrates from North to South and basin floor fans are from West to East directions

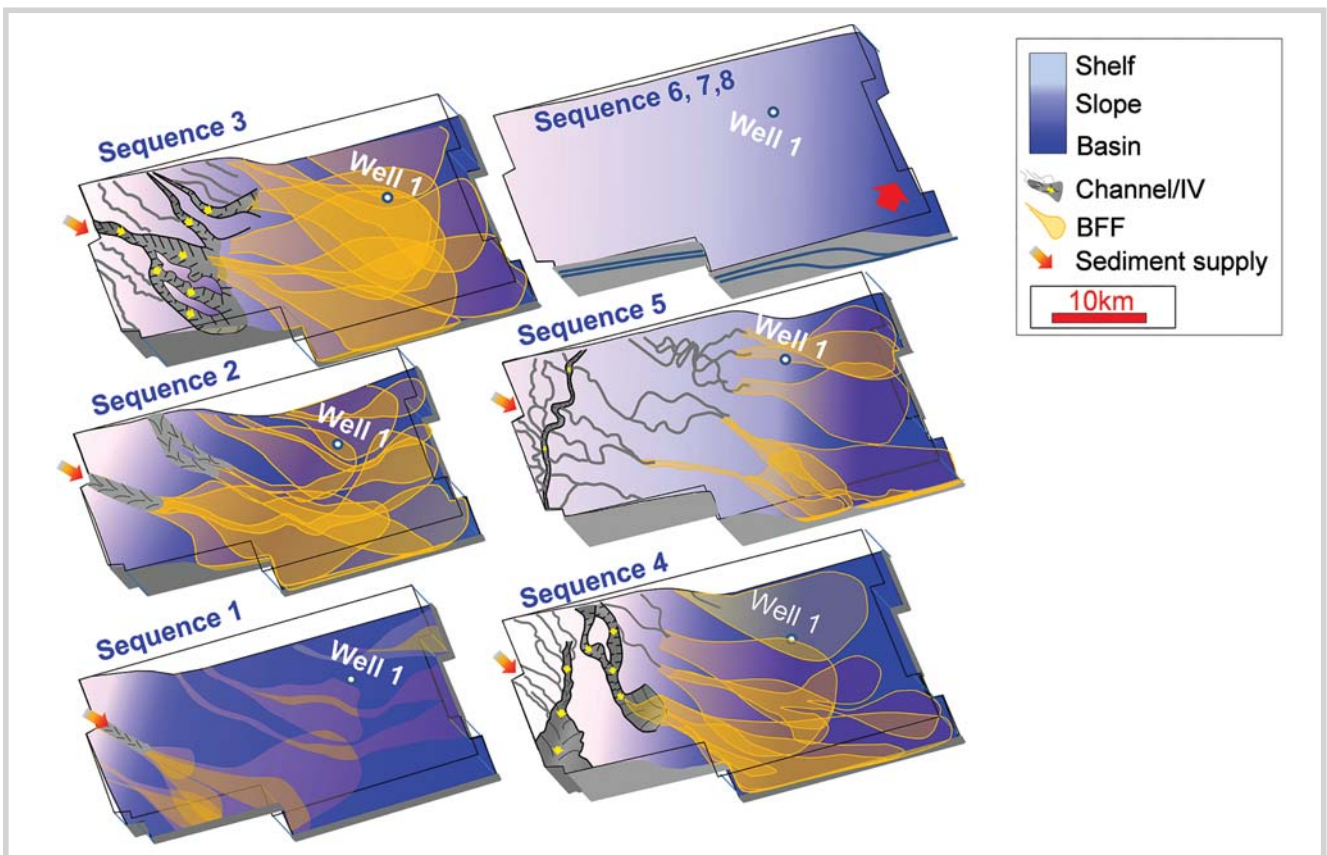

Figure 8. Channels and basin floor fans are displayed on the depositional environment map

By combination of root mean square (RMS) maps with well log, the sand/shale of basin floor fans of each sequence can be interpreted (Figure 6). The evolution of channels/incised valleys on shelf can be seen on RMS maps and on the time slices. In addition, the evolution of basin floor fans can be predicted and mapped through time (Figures 7 and 8).

Almost all channels developed through time have a main flow direction from west to east, while the channels within sequences S4 and S5 have a trend from north to south. On the other hand, basin floor fans have a main direction of sediment supply from west to east as shown in Figure 8.

In terms of finding exploration targets, geometries of channel or incised valleys and basin floor fans were defined based on seismic attributes. However, it is more important to predict lithology facies filled in channels or all incised valleys and lithology of basin floor fans. From seismic attribute maps, almost all basin floor fans with thickness changing from 20ms (approximately 20m) of sequences 4 and 5 to 100ms (approximately 100m) of sequences 1 and 2 and special sequence 3 have sand dominated as high amplitude on RMS map.

4. Conclusions

Eight sequence boundaries within the Pliocene-Pleistocene sections were interpreted on integration of seismic and well data. The system tracts of each sequence were defined confidently. Based on seismic sections, maps and seismic attribute analyses, channels or incised valley systems and basin floor fans were detected and mapped. The Gross Depositional Environment map was also interpreted aiming for better visualisation of the process of how the sediments were deposited and developed.

References

1. C.M.Wright. *Neogene stratigraphy relationships within the Nam Con Son basin, offshore Vietnam resulting from tectonics, eustasy, and sediment flux*. A&M University, Texas. 2006.
2. Dominic Emery, Keith Myers. *Sequence stratigraphy*. Blackwell Science Ltd. 1996.
3. O.Catuneanu. *Principles of sequence stratigraphy*. Elsevier B.V. 2006.
4. G.A.Kirby. *Sequence stratigraphy of hydrocarbon basins of SE Asia*. British Geological Survey. 1995.
5. Walter W.Wornardt Jr, Bernard L.Shaffer, Peter R.Vail. *Revision of the Late Miocene, Pliocene and Pleistocene sequence cycles*. Gulf Coast Association of Geological Societies Transactions. 2001; 51: p. 477 - 481.
6. B.Katz. *Lacustrine basin hydrocarbon exploration - Current thoughts*. Journal of Paleolimnology. 2001; 26(2): p. 161 - 179.
7. Lincoln F.Pratson, Bernard J.Coakley. *A model for the headward erosion of submarine canyons induced by downslope-eroding sediment flows*. Geological Society of America Bulletin. 1996; 108(2): p. 225 - 234.
8. Francis P.Shepard. *Submarine canyons; multiple causes and long-time persistence*. American Association of Petroleum Geologists Bulletin. 1981; 65: p. 1062 - 1077.
9. J.Sotak, M.Perezslenyi, R.Marschalko, J.Milicka, D.Starek. *Sedimentology and hydrocarbon habitat of the submarine-fan deposits of the Central Carpathian Paleogene basin (NE Slovakia)*. Marine and Petroleum Geology. 2001; 18 (1.1): p. 87 - 114.
10. Eduard Suess. *Das antlitz der erde - Volume II: Die meere der erde*. Wien. 1888.
11. W.F.Tanner. *Tertiary sea level symposium*. Palaeogeography, Palaeoclimatology, Palaeoecology. 1968; 5.
12. D.C.Twichell, D.G.Roberts. *Morphology, distribution, and development of submarine canyons on the United States Atlantic continental slope between Hudson and Baltimore canyons*. Geology. 1982; 10(8): p. 408 - 412.
13. P.R.Vail, R.M.J.Mitchum, S.Thompson. *Seismic stratigraphy and global changes of sea level, Part 3: Relative changes of sea level from coastal onlap*. AAPG Memoir: Seismic Stratigraphy - Applications to Hydrocarbon Exploration. 1977; 26: p. 63 - 81.
14. P.Veecken, B. van Moerkerken. *Seismic stratigraphic techniques. Seismic stratigraphy and Depositional facies models*. EAGE and Elsevier Scientific Publishers. 2013: p. 107 - 214.
15. F.Mattern. *Ancient sand-rich submarine fans: depositional systems, models, identification, and analysis*. Earth-Science Reviews. 2005; 70(3 - 4): p. 167 - 202.
16. J.Wang, H.Chen, H.Wang, T.Jiang, H.Miao, Y.Shang. *Depositional characteristics of the large-scale sublacustrine fan at member Yong 1 of the Yitong Graben and its response to tectonic events*. Acta Geologica Sinica. 2009; 83 (4): p. 550 - 557.

OPTIMAL WELL PLACEMENT TECHNIQUES IN LOW CONTRAST CLASTIC RESERVOIRS UTILISING INTEGRATED TECHNOLOGIES AND REAL-TIME DATA TO MINIMISE UNCERTAINTY IN CHALLENGING LOW CONTRAST CLASTIC RESERVOIRS

Phung Nguyen Thanh¹, Jacob Doogue¹, Gagok Santoso¹, Wanmun Park¹, Tanawut Khunaworawet¹

Kulapat Wattana¹, Rattana Watcharantakul², Svein T. Opdal², Suebthep Thepparak²

Wattanaporn Phaopongklai², Chaiyos Thurawat², Ian McManus², Ikenna Chigbo²

¹Schlumberger Oilfield Services

²Mubadala Petroleum

Email: Tnguyen36@slb.com

Summary

Nong Yao is an oil field with complex geology setting: the extent of aquifer support, faulted and compartmentalised reservoirs, lateral sand connectivity, thin oil columns, fluid contact, and low contrast pays. It is very challenging to develop the field with conventional methodology by drilling highly deviated or slanted wells. Utilising and integrating technology and real-time data geo-steering was enabling the success of development plan by minimising those uncertainties, landing the wells and geo-steering the horizontal well precisely as desired. As the result, the production increased significantly and it becomes the potential to unlock more reservoirs in the Gulf of Thailand for development in the current cost pressure and oil price environment.

Key words: Low contrast, thin channel sand, horizontal geo-steering, field development, production, real-time.

The Nong Yao field is located in the southern Gulf of Thailand, approximately 145km off the coast, in approximately 75m of water. The Nong Yao field covers the southern margin of Pattani basin and the north west border of the Malay basin. It was discovered by Nong Yao-1 exploration well in 2009 (Figure 1). The key subsurface challenges and uncertainties in the Nong Yao clastic reservoirs were: limited exploration and appraisal data, the extent of aquifer support, faulted and compartmentalised reservoirs, lateral sand connectivity, thin oil columns, fluid contact, low contrast pays and geological structure. The strategy to develop the Nong Yao field was via horizontal wells in order to maximise the reservoir exposure in thin sand reservoir to optimise the field production. This paper will cover some of the techniques used in placing the horizontal wells, which include utilising technologies to overcome difficulties, minimising uncertainties, dealing with reservoirs of low contrast and integrating and using data in real-time for better decision making.

All of the planned well trajectories were based on the depth converted seismic, inversion porosity cube and available appraisal well data. However, the appraisal well data was limited thus the planning phase had to heavily rely upon seismic. Due to the seismic depth uncertainty, landing wells in the target sand is always a challenging task

for the Nong Yao subsurface team. The first challenge was the thin sandstone reservoir targets, some with gradational resistivity profiles changing from shale to shaly sand, to sand. Others with low contrasts between oil pay sand and surrounding shales, and other with gas bearing sands had a similar resistivity to oil filled sands. This can make differentiating the oil sand pay from either shaly wet sand



Figure 1. The Nong Yao field location map

or gas bearing sands difficult. Additionally, many reservoirs having either oil on water or gas on oil on water, the depth and reservoir identification become critical to the success of landing and placing the horizontal well. If the well was landed too shallowly, critical pay footage would be missed. Conversely, if the well was landed too deep, it would lead to early water break-through. None of those scenarios are desirable for long-term production outcomes. Therefore, if the wells are not correctly landed, the consequences would be a costly plug back and side-track would be required.

The first case study from the Nong Yao field is the drilling of well A into C sandstone reservoir. Well A was a horizontal development well to optimise the production of the C sandstone reservoir. Figure 2 illustrates that the fault separates the C sandstone reservoir into two sand bodies located in different fault blocks. In the left side fault block, the appraisal well D shows the sand C thickness approximate 20ft TVT. The reservoir has a thin gas interval on top of oil, with a gradational transition from the shale into the clastic reservoir. The gamma ray (GR) reduces from 160 GAPI in the shale to 90 - 110 GAPI in the shaly top, and down to 60 - 80 GAPI in the cleanest part of the sand. Similarly, the resistivity profile is more gradational from 4Ω.m in shale, to 12Ω.m in gas, gradually increasing to between 20 - 40Ω.m in the oil pay. Sand C in well D could only be used as a guide as to what to expect in well A, as there were not any control or pilot wells in the right fault block. Therefore, landing the well was challenging because of the depth uncertainty of the top sand reservoir. Moreover, there was also uncertainty on fluid types and contacts (gas on oil, oil, or oil

on water) that were found in well D but were unknown in well A.

Following traditional development and well placement techniques, it was proposed to drill a separate pilot hole first through sand C in the right fault block in order to understand the structure and contacts inside the reservoir before drilling the development horizontal well A. However, separate pilot holes can be very costly. Understanding the situation, a solution was proposed to use a new well placement technique, utilising new technology in order to accurately land the well in real-time utilising a single well. The technology is a reservoir-mapping-while-drilling tool that uses ultra-deep azimuthal electromagnetic propagation measurements through a complex inversion that can map resistivity contrasts and boundaries in the formation at a distance of up to 100ft TVD. This deep mapping can help to detect boundaries well before the drill bit enters, which enables the depth uncertainty of formation tops to be reduced in real-time to optimise the landing point. In addition, a high build rate hybrid rotary steerable (RSS) tool was chosen to enable swift trajectory changes when required, combined with triple combo integrated logging-while-drilling (LWD) tool, just behind the RSS for differentiation between oil and gas via neutron-density cross over.

Pre-job planning is essential to success and critical to using ultra-deep resistivity tools is to model the inversion result based on the best available data, and the possible scenarios expected. Well A was modelled by using the offset well logs properties (well D) and structure from seismic data. The modelling result showed that the top of the C sandstone reservoir could be mapped at approximately 40ft TVD below the well trajectory when the well approaches the top C at 83 - 84deg

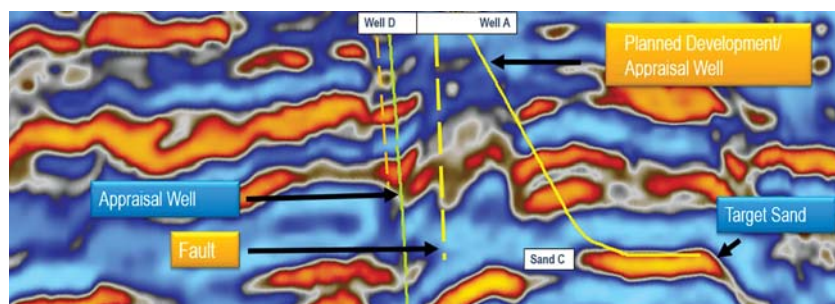

Figure 2. Seismic cross section for well A planning

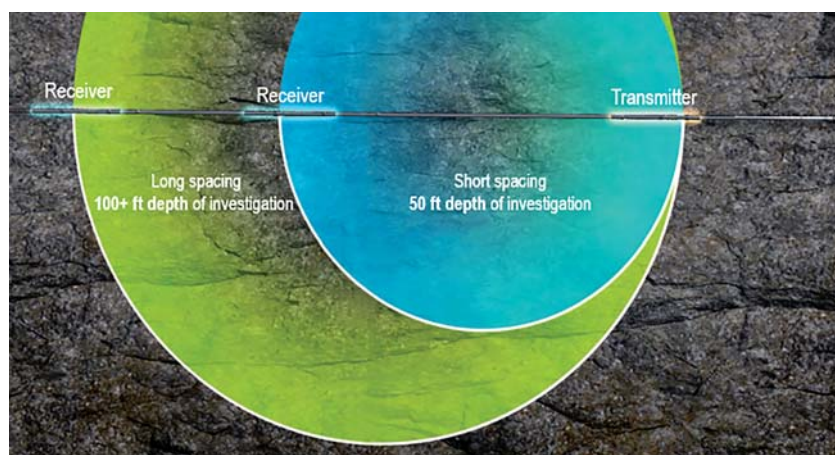

Figure 3. Ultra-deep azimuthal resistivity tool's depth of investigation

inclination, based on the expected resistivity contrast between shale and reservoir. It is equivalent to 300 - 350ft MD before hitting the top C target. By mapping the top C in advance, it gave the team adequate time to revise the well plan and land in the updated top C target. The landing of well A was executed successfully. Ultra-deep azimuthal resistivity inversion mapped the top C sandstone reservoir at 7XXXft MD/2XXXftTVD, approximately 45ftTVD below the well path. The top sand was 20ft TVD deeper than the prognosed top based on seismic. The detection range was 5ft TVD greater compared with pre-job modelling. Finally, well A was landed successfully inside the C sandstone reservoir as desired.

In addition, the reservoir mapping while drilling also detected the lower boundary of the sand, which was then used to provide the thickness of the pay interval in real-time. This could quickly be used to perform volumetric calculations, to help determine well economics and enhance decision making, in real-time, which could not be achieved with seismic and traditional LWD alone.

The second case study is the horizontal well A1 drilling into reservoir C1. The sand C1 reservoir is thin (approximately 8 - 10ft TVT) and has low resistivity contrast with surrounding shaly sand. Figure 5 illustrates the resistivity and GR profile of the sand C1 reservoir. There is a low contrast between the shale resistivity and sand resistivity (shaly sand is 6 - 8Ω.m and sand is 9 - 12Ω.m) thus it is easy to place the well into the shaly sand layer instead of good sand layer. A deep azimuthal resistivity tool with distance to boundary mapping was proposed for horizontal geo-steering in order to stay in the reservoir as much as possible. Pre-job modelling was performed before each horizontal well to confirm that the

boundaries could be mapped even in challenging low contrast conditions. A real-time inversion provided valued information of the boundary distance to the well bore and we can geo-steer the well confidently and precisely.

The distance-to-boundary inversion was used for the entire horizontal interval of well A1. It mapped the upper boundary for the first half of the horizontal section approximately 3 - 5ft TVD above the well path and the well was precisely placed under the top. For the second half of the horizontal section, it mapped the reservoir profile clearly with the shale and shaly sand layer. The sand quality changed, approximately two-thirds along the horizontal and the well penetrated the shaly sand layers and followed the shale boundary. Finally, well A1 was placed close to the top of the reservoir as desired. Without the “distance-to-boundary mapping” tool, there would not be a clear reference point to geo-steer and steering would be reliant on seismic data and basic real-time data. If so, well A1 would not be placed precisely within 3 - 5ft of the top of the structure. The result would be early water breakthrough and less oil production, which clearly shows the benefit of using distance-to-boundary technology to optimally place the horizontal well. Applying the same methodology, all the horizontal wells for Nong Yao development were placed successfully by using distance-to-boundary

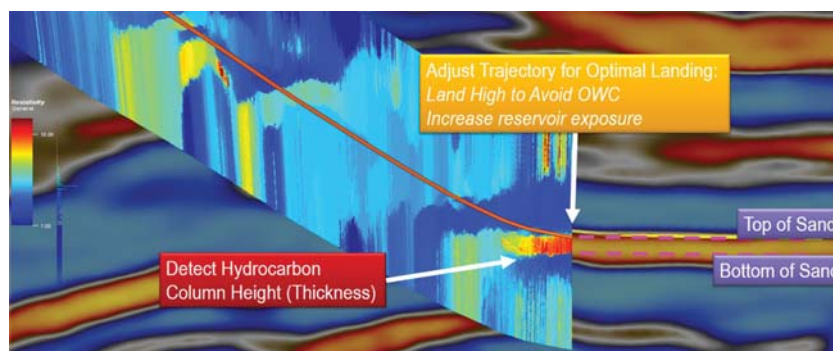

Figure 4. Ultra-deep azimuthal resistivity inversion mapped the top of sand C reservoir when landing well A

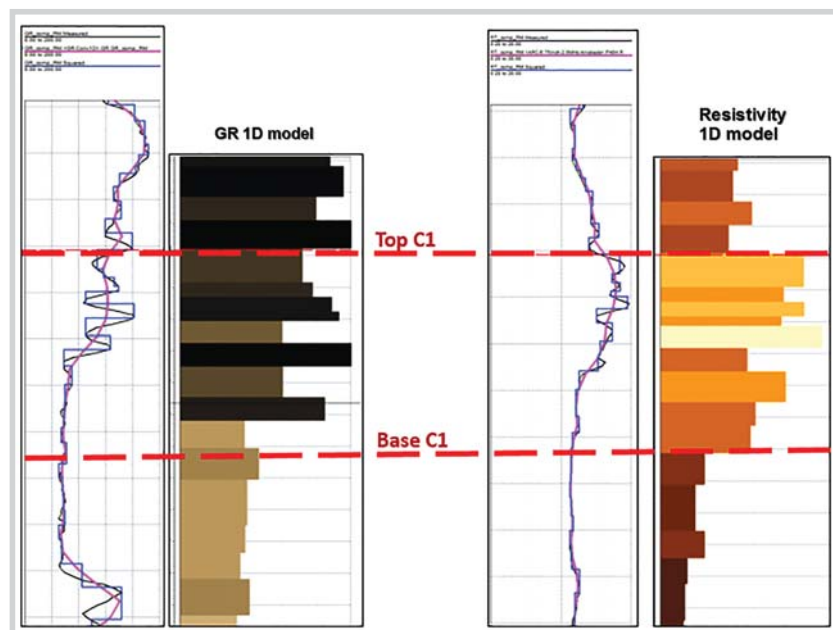

Figure 5. Offset well log properties

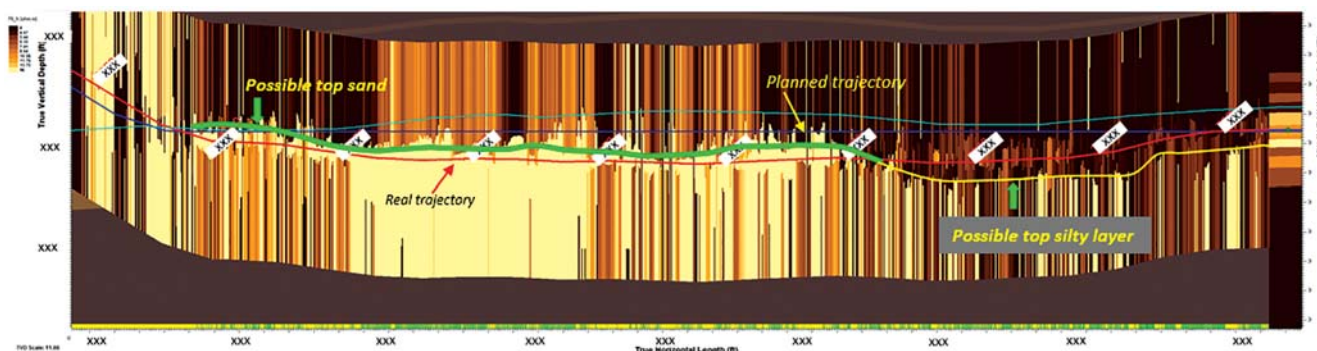

Figure 6. Horizontal section of well A1

mapping for optimising horizontal well position and improving the production.

The well A case shows that innovative use of ultra-deep azimuthal resistivity combined with LWD near-bit triple combo enabled Mubadala Petroleum to save the cost of a separate appraisal well. Key LWD data was used to make real-time decisions, changing the well path and landing point and reducing the structural and volumetric uncertainty. While the well A1 case shows that the right selection of technology will help to optimally drill and place horizontal wells to optimise the production and the well lifetime. For the whole Nong Yao development project, this methodology in overall reduced 25% development or drilling costs while developing additional resources, and achieving target production:

Appraisal while drilling optimised well locations, leading to cancellation of multiple water injection not required, resulting in substantial well cost savings;

Distance-to-boundary LWD geo-steered wells in sands and also mapped top and extent of structures, improving volumes and drainage areas;

Ultra-deep azimuthal resistivity, the first use of the technology in Thailand, with LWD triple combo enabled reservoir mapping and the elimination of a separate pilot well.

Conclusions

The Nong Yao development methodology and well placement techniques provide a model strategy for how development can be approached in order to reduce overall development costs, in turn making reservoirs more viable to develop. The integrated approach to the use of technology, planning techniques and well placement techniques in challenging environments sets a benchmark for clastic reservoir development in the Gulf of Thailand. The value and impact to Thailand's Oil and Gas Industry is significant, as it has the potential to unlock more reservoirs in the Gulf of Thailand for development in the current cost pressure and oil price environment.

References

1. Roger Griffiths. *Well placement fundamentals*. Schlumberger. 2009.

This paper was prepared for presentation at APPG Geosciences Technology Workshop "Characterisation of Asian Hydrocarbon Reservoirs" Bangkok, Thailand. 31 March - 1 April 2016.

SOME SOLUTIONS TO IMPROVE THE CEMENT BOND QUALITY FOR CARBONATE ZONES IN BLOCK 05-1A, OFFSHORE VIETNAM

Le Vu Quan¹, Vu Duc Ung¹, Pham Hong Trang¹, Le Thi Thu Huong¹, Nguyen Manh Tuan², Do Huu Trung²

¹Vietnam Petroleum Institute

²Petrovietnam Domestic Exploration Production Operation Company Limited

Email: quanlv@vpi.pvn.vn

Summary

Cement work at Dai Hung wells has faced many problems with carbonate zones. Improving the cement bond across carbonate reservoirs to avoid remedial cement works and production problems is very critical for future drilling in Dai Hung field. The article presents the results of substantial study to find out the most suitable type of cement, formula, properties and cementing tools for cementing carbonate zone sections.

Key words: Cement bond, carbonate zone, Dai Hung well, cementing solution.

1. Introduction

PVEP POC has been drilling many exploration, appraisal and production wells (22 exploration/appraisal wells and 19 production wells) in Block 05-1a (Dai Hung field), which is located in the north-western part of Nam Con Son basin. For cementing service of these wells, PVEP POC has been using different cementing companies and cement slurry types. However, cement bonds across carbonate zones were not qualified in terms of zone isolation that resulted in spending rig time on remedial cement squeeze works and causing a problem with well production later on.

In the past, the incidents of gas blow when entering the DH-8X and the well control problem with the DH-13P drilling operation were all related to the poor cement bond across carbonate section. Specially, the recent incident of gas leaking on the 18¾ inch subsea wellhead of DHN-1X had a root cause of poor cement quality behind 9⅝ inch casing. Therefore, it is essential to study and find suitable kinds of cement for the carbonate zones.

2. Cement bond issues in Block 05-1a

From the drilling database of Dai Hung wells drilled between 2013 and 2015, the high mud loss rates were encountered while drilling across the carbonate reservoir zones. These loss rates of drilling fluid through the fractured limestone (carbonate reservoirs) cannot be completely treated by conventional methods (pumping CaCO₃ LCM) [1]. Besides that, no cement or permanent lost circulation materials were allowed to pump as they could permanently damage these potential reservoirs. As the wells were still in the partial loss condition, the conventional cement slurries were lost into fractured

zones during cementing 9⅝ inch casings. Subsequently, this resulted in poor cement quality through the limestone and the top of cement dropped lower than the plan [1].

With poor cement quality behind the casings and the characteristics of interbedded layers containing water, oil and gas, it was an issue for zone isolation when the well was completed and put into production. The water or gas would leak into the oil zones and caused the reduction of oil production. Therefore, technically, remedial cement squeeze works were required to improve the zone isolation prior to completing the wells. Time for each cement squeeze work was from 3 to 7 days, thus it increased the well costs and could pose a risk of reservoir damage during this remedial work. In 2014 and early 2015, a total of 17 remedial cement squeeze works were conducted due to poor quality cement across carbonate zones for wells DH-21XP, 22XP, 18P, 23XP, 10PST and DHN-1X [1].

3. Proposed cement bond improvement study

3.1. Laboratory testing results of new cement slurry type for carbonate formations

Many laboratory tests were performed using special cement materials to design a suitable lightweight cement slurry for cementing the 9⅝ inch casing on well DHN-1X. Laboratory testing results for new cement slurry type are shown in the following tables:

Table 1. Well information

Casing/Liner size	9⅝ inch
Hole size	12¼ inch
Pressure	440bar/6,377psi
Depth MD	3,435m/11,270ft
Depth TVD	3,109m/10,201ft
Bottom hole static temperature (BHST)	130°C/266°F
Bottom hole circulating temperature (BHCT)	96°C/205°F

Table 2. Cement information - Lead design

Concentration	Unit of measure	Cement/Additive	Sample date (dd.mm.yy)	Lot No.	Cement properties	
100.00	% BWOC	Holcim class G			Slurry density (lbm/gal)	11.5
10.95	gal/sack	Sea water			Slurry yield (ft ³ /sack)	3.1535
15.00	% BWOC	HGS 8000X (PB)			Water requirement (gal/sack)	10.9547
2.50	gps	Silicalite liquid	11.11.14		Total mix fluid (gal/sack)	14.39
0.05	gps	D-Air 3000L	14.11.14			
0.50	gps	HALAD-344EXP	13.09.14	309471		
0.14	gps	SCR-100L	20.11.14	310044	Water source	Sea water
0.30	gps	CFR-3L	11.11.14		Water chloride	N/A
35.00	% BWOC	SSA-1 (silica flour) - PB				

Table 3. Pilot test results [1, 2]

Mixability (0 - 5) - 0 is not mixable											
Mixability rating (0 - 5)						Average round per minute mixing under load (~12,000)					
4						12,000					
API rheology											
Temperature (°F)	600	300	200	100	60	30	6	3	Conditioning time (min)	Plastic viscosity/Yield point	
	190	270	162	121	74	56	37	15	11	30	148/19
Thickening time											
Temperature (°F)	Pressure (psi)	Reached in (min)		Start BC	30 Bc (hh:mm)	50 Bc (hh:mm)	70 Bc (hh:mm)	100 Bc (hh:mm)			
205	6,377	145		10	05:00	05:14	05:20	05:25			
UCA compressive strength (CS)											
End temperature (°F)	Pressure (psi)	50psi (hh:mm)		500psi (hh:mm)		12 hours CS (psi)		24 hours CS (psi)			
266	3,000	03:35		05:05		1,074.38		1,231.29			
API fluid loss											
Test temperature (°F)	Test pressure (psi)	Test time (min)	API fluid loss (cc/30min)		Measure volumne	Conditioning time (min)					
190	1,000	30	30		15	30					
Static gel strength											
Temperature (°F)	Time CSGS (hh:mm)	Time 100 lb/100ft ² (hh:mm)	Time 200 lb/100ft ² (hh:mm)	Time 300 lb/100ft ² (hh:mm)	Time 400 lb/100ft ² (hh:mm)	Time 500 lb/100ft ² (hh:mm)					
266	00:37	04:14	04:31	04:39	04:49	04:51					
Crush compressive strength											
Conditioning time (min)	Curing temperature (°F)	Curing pressure (psi)	Time 1 (hours)	Strength 1	Time 2 (hours)	Strength 2	Foam Q (%)				
48	266	3,000	48	1,400	48	1,295	0				

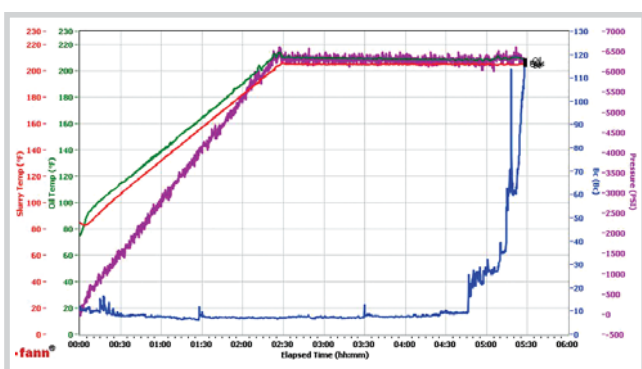

Figure 1. Transition time chart result [2]

From the above laboratory testing results, it was obvious that the new cement slurry (lightweight - tuned light) can be designed at low density (11.5ppg for this case) but still provide good compressive strength of ~1,250psi at 24 hours to ensure a good zone isolation.

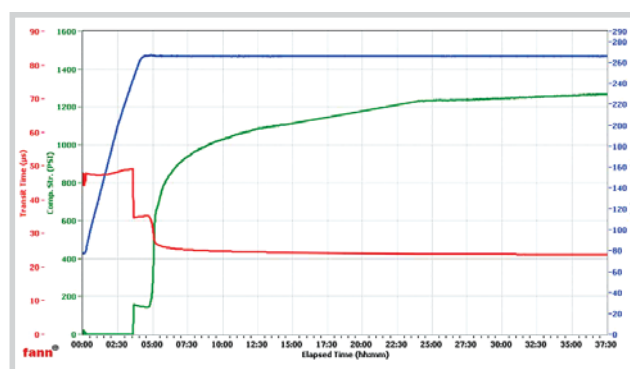

Figure 2. Ultrasonic cement analyser chart result [2]

3.2. Laboratory testing results for the new cement spacer to be applied for carbonate formations

Figure 5a presents the hydraulic bond strength, shear bond strength and compressive strength for the dry

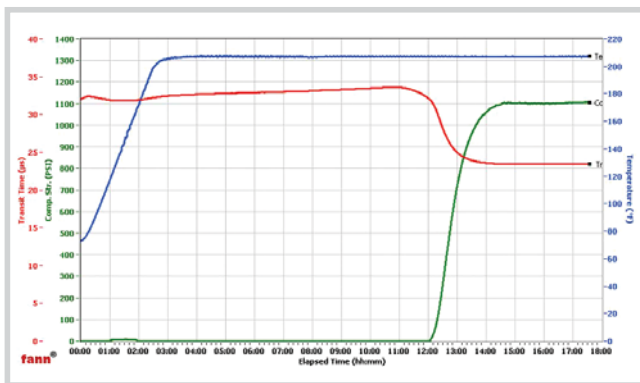

Figure 3. UCA result at 13³/₈ inch shoe [2]

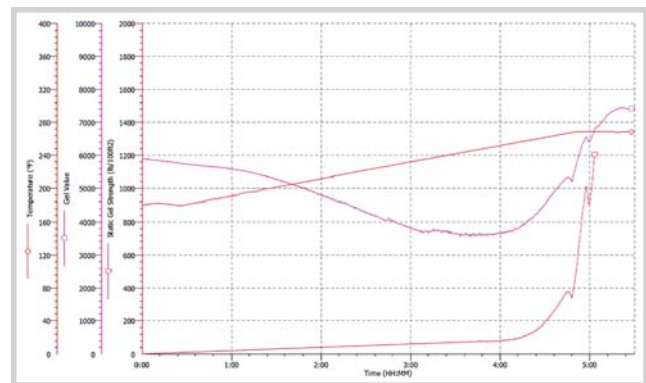
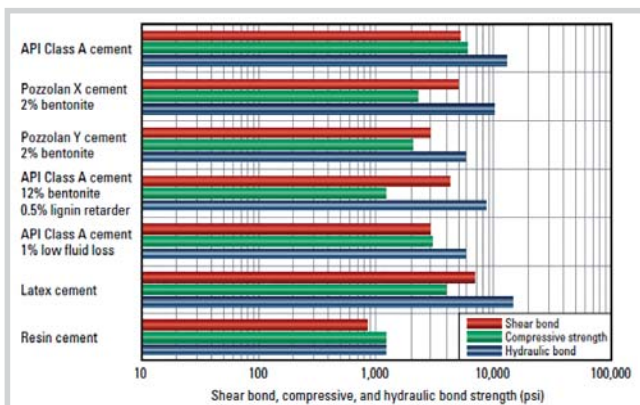
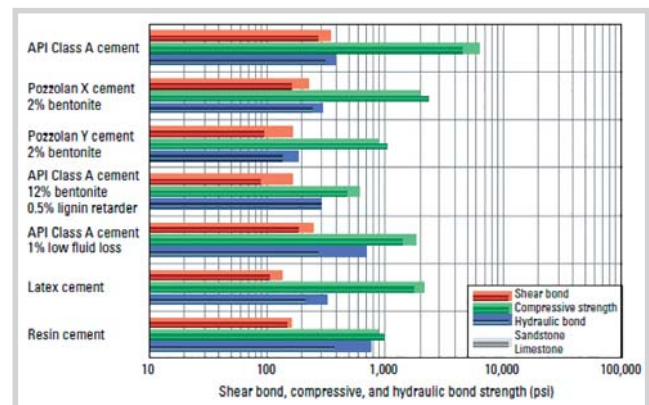

Figure 4. Static transition time result [2]



(a)



(b)

Figure 5. Bond strength of dry core by cementing with different kinds of slurries (a); Bonding strength of a core after treatment with water-based drilling mud and then placed against different slurries after the removal of mud cake (b) [3]

limestone. Seven different kinds of cements were placed against the dry limestone. According to that, bonding strengths are maximum in case of using API class A cement and Latex cement.

In the next case, cores were firstly treated with water-based drilling mud. Then the cement was squeezed against the cores at a pressure of 100psi. The mud cake was removed in this case. A significant decrease in shear bond strength can be observed in Figure 5b as compared to the dry cores.

Based on the lost circulation condition of 12¹/₄ inch hole section of Dai Hung wells, it is very important to have a new cement spacer which can provide both mud cake removal and loss curing effectiveness.

The SealBond cement spacer is a new cement spacer which can aid in reducing lost circulation problems in fragile, unconsolidated and fractured carbonate formations. It will form a non-evasive seal to minimise filtrate invasion into the formations to “only inches” and work with differential pressure - high regained permeability. Spacer mixture viscosity can be adjusted to help cleaning the mud from the hole and increasing

sealing properties. SealBond Plus lost circulation material can be added into this spacer in cases of severe to total loss circulation. For each cement job, a volume of 50 - 100bbl of this spacer can be pumped ahead of cement slurry to help improve the cement bond quality.

3.3. Proposing the best cement system

3.3.1. Tuned light cement system - lightweight cement

High-strength performance from a lightweight slurry. Tuned light cements rely on microspheres to produce lightweight slurries with excellent strength characteristics. Tuned light cement can yield strengths equal to or better than cements of equal density made by any other lightweight technique. Advantages of tuned light cement include low density, thixotropic, faster transition times and compressive strength [4].

3.3.2. Tuned light cement system - Technical information

- Tuned light low-density slurry system:

Depending on the required slurry density, the tuned light system base blend may include the following materials:

- Various types of cement (API Class A, C, G, and H).

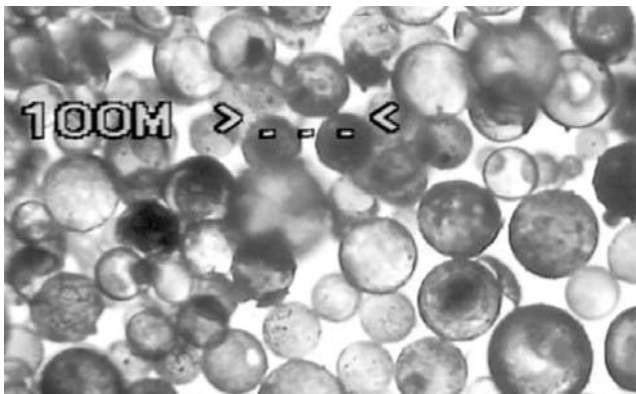
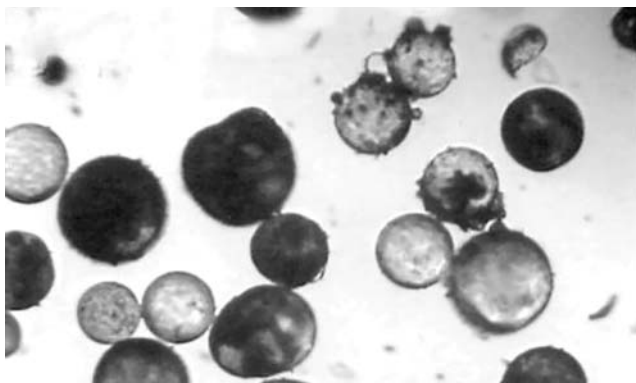

Figure 6. MetaspHERE 50 microspheres at 0psi [2]

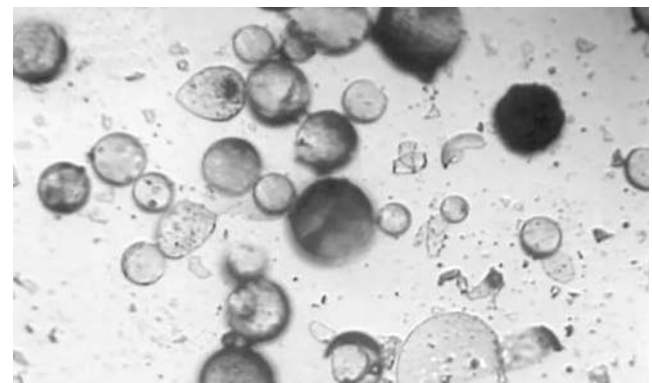

Figure 7. MetaspHERE 100 microspheres at 0psi [2]



(a)

Figure 8. MetaspHERE 50 microspheres: (a) 0psi, (b) 4,000psi [2]



(b)

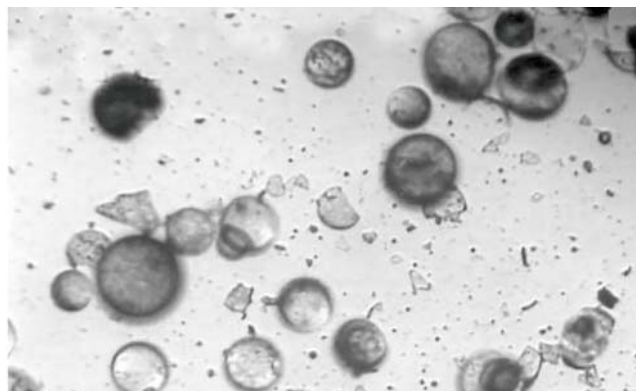

(a)

Figure 9. MetaspHERE 100 microspheres: (a) 0psi, (b) 4,000psi [2]

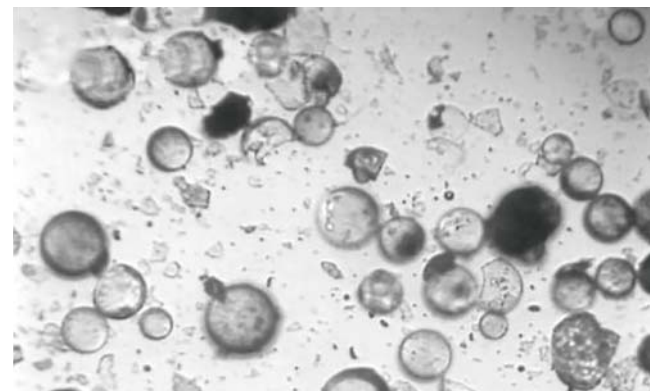

(b)

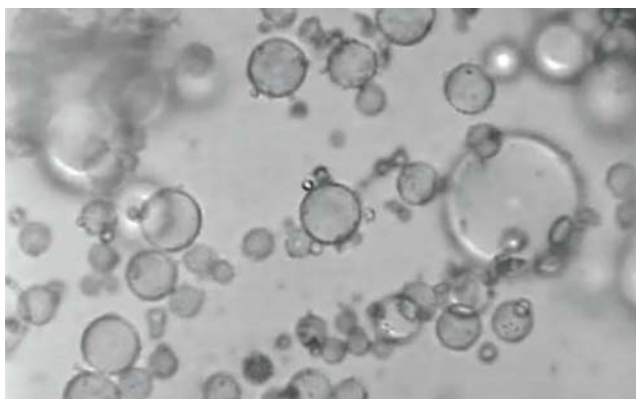

(a)

Figure 10. 3M glass bubbles S38HS: (a) 0psi, (b) 4,000psi [2]

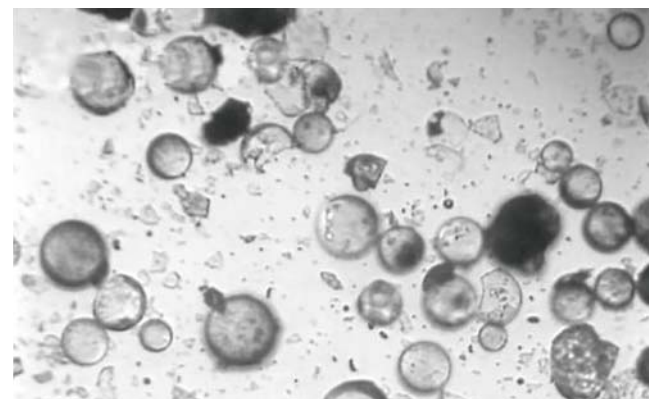

(b)

- Micro matrix cement, FineCem cement blend, or Enhancer 923™ additive.
- Silicalite additive.
- Hollow microspheres.
- + Spherelite additive (Metasphere 50, Metasphere 100).
- + 3M Scotchlite glass bubbles.
- Universal cement additive material.

The tuned light system can be stabilised for high-temperature applications by incorporating SSA-1, SSA-2, or MicroSand cement additives. The system is compatible with all cement additives, such as retarders, fluid-loss additives,

free-water materials, and suspension additives. The tuned light system can be formulated for use in any application requiring a low-density slurry, such as cementing offshore conductor casing, cementing casing in weak or fractured carbonate formations, cementing in geothermal wells, and cementing in fragile permafrost formations.

- 3M Scotchlite glass bubbles (Synthetic hollow spheres) are shown in Figure 10 and 11.
- Tuned night system designs:

The basic tuned light system has been developed and composed of different additives and/or microspheres. Each design was tested to meet common customer criteria for low-density cements (Table 4).

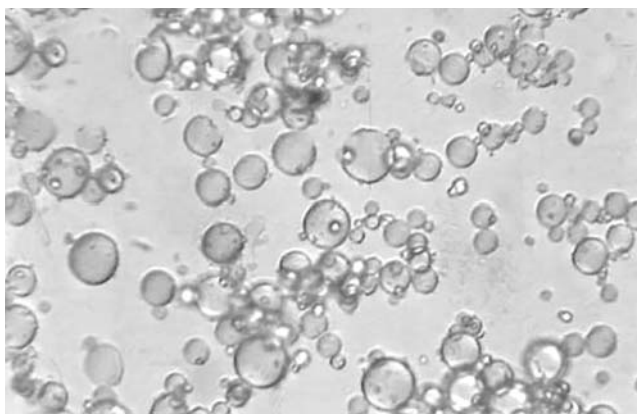

(a)

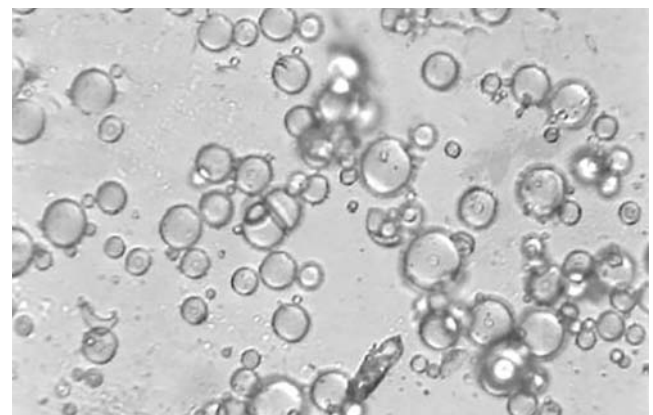

(b)

Figure 11. 3M glass bubbles S60 (a) 0psi, (b) 4,000psi [2]

Table 4. Physical properties of tuned light system

Slurry No.	Surface density (lbm/gal)	Density at 4,000psi (lbm/gal)	Yield at 4,000psi (ft ³ /sk)	Water (gal/sk)
1	6	6	11.31	30.38
1R	6	6	-	-
1A1	6	6	7.51	21.01
1A2	6	6	7.51	21.01
1B	6.45	6.5	9.31	27.77
2	7	7	8.37	24.93
2A	7	7	14.35	45.15
2B	7	7	14.4	45.15
2C	7.5	7.5	5.73	16.93
2D	7.5	7.5	18.06	6.16
3A	7.95	8	7.41	20.32
3B	8.02	8	7.83	22.57
3C	7.93	8	7.67	21.44
4A	9	9	4.67	13.83
4B	9	9	5.05	15.59
4C	9	9	4.86	15.16
5A	10	10	3.46	11.06
5B	10	10	3.71	12.16
5C	10	10	3.39	9.26
6	9.3	11	3.36	10.89
7	11.15	12	2.53	9.57
8	12.69	13	2.01	7.43

Table 5. Tuned light system blend design

Slurry No.	PZ-55 cement (lbm)	Micro matrix cement (%)	Silicalite additive (%)	KCI (%)	CFR-3 dispersant (%)	Halad-344 fluid- loss material (%)	Halad-413 fluid- loss material (%)	UCA (%)	Diacel LWL retarder 90°F CT 120°F ST (%)	HR-5 retarder ISO/F CT 200°F ST (%)	D-Air 30 OOL Defoamer (gal/sk)	Spherelite additive/ metasphere 50 microspheres (%)			3M scotchlite glass bubbles		
												S60 (%)	S385 (%)	K46 (%)	S60 (%)	S385 (%)	K46 (%)
1	94	-	-	-	0.43	0.43	0.85	-	-	-	0.05	-	-	170.9	-	-	-
1R"	-	-	10	-	-	-	-	-	-	-	-	-	40	-	-	-	-
1A1	-	-	-	3	4.0	-	3.0	-	-	0.7	-	-	-	207	-	-	-
1A2	-	-	-	3	4.0	-	3.0	-	-	1.5	-	-	-	207	-	-	-
1B	94	-	-	3	0.64	0.43	0.85	-	-	-	0.05	-	-	128.2	-	-	-
2	94	-	-	-	0.43	0.43	0.85	-	-	-	0.05	-	-	-	-	145	-
2A	94	100	-	3	4.0	-	4.0	-	-	1	-	-	-	181	-	-	-
2B	94	100	-	3	4.0	-	3.0	-	-	2.5	-	-	-	182	-	-	-
2C	94	15	-	3	-	-	2.0	-	-	1.0	-	-	-	73	-	-	-
2D	94	15	10	3	1.4	-	2.0	-	-	0.5	-	-	-	78.5	-	-	-
3A	94	-	15	5	2.0	0.5	1.0	0.5	0.1	0.4	0.05	-	160	-	-	-	-
3B	94	-	15	5	2.0	0.5	1.0	0.5	0.2	0.4	0.05	-	160	-	-	-	-
3C	94	15	-	5	2.0	0.5	1.0	0.5	0.3	0.5	0.05	-	165	-	-	-	-
4A	94	-	15	5	2.0	0.5	1.0	0.5	0.2	0.4	0.05	-	85	-	-	-	-
4B	94	-	15	5	2.0	0.5	1.0	0.5	0.2	0.4	0.05	-	82	-	-	-	-
4C	94	15	-	5	2.0	0.5	1.0	0.5	0.3	0.4	0.05	-	87	-	-	-	-
5A	94	-	15	5	2.0	0.5	1.0	0.5	0.2	0.4	0.05	-	53	-	-	-	-
53	94	-	15	5	2.0	0.5	1.0	0.5	0.4	0.4	0.05	-	47	-	-	-	-
5C	94	15	-	5	2.0	0.5	1.0	0.5	0.05	0.6	1.1	-	55	-	-	-	-
6	94	-	15	5	1.0	0.5	1.0	0.5	0.2	0.4	0.05	-	-	-	80	-	-
7	94	-	15	5	1.0	0.5	1.0	0.5	0.2	0.4	0.05	-	-	-	40	-	-
8	94	-	15	5	2.0	0.5	1.0	0.5	0.2	0.4	0.05	-	-	-	25	-	-

4. Proposing new cementing tools to be applied as two-stage tool, inflatable packers

4.1. Two-stage cementing tool

With the use of multiple-stage cementing tools, cement slurry can be placed at selected intervals around the casing string (Figure 12).

4.2. External sleeve inflatable packer collar (ESIPC™) tool

The external sleeve inflatable packer collar (ESIPC™) tool is a combination of the ES (type P or type H) cementer and a casing inflation packer. This tool provides a controlled packer element inflation through the stage-tool opening seat, eliminating hydraulic valve bodies normally used with inflatable packer elements. The ESIPC tool is commonly used in horizontal well applications for cementing casing in the bend radius or vertical portion of the wellbore, above an openhole completion or a slotted liner [4].

- Multi-stage inflatable packer collar (MSIPC):

The multi-stage inflatable packer collar (MSIPC) is a combination of the reliable plug-operated Halliburton MS cementer tool and a metal bladder casing inflation packer. This economical tool provides controlled packer element inflation through the stage-tool opening seat, eliminating hydraulic valve bodies normally used with inflatable packer elements. The metal bladder tools are recommended for use when setting a hard rock formation or inside casing [5].

- Multi-stage packer cementing collar (MSPCC):

The multi-stage packer cementing collar (MSPCC) is a stage cementer with an integral, solid rubber, compression-set packer element. Like the other stage-cementing packer collars, the MSPCC is used either to prevent gas migration or to support the hydrostatic pressure of the cement with a packer. However, the compression-set (or mechanical) packer elements, that do not hold as much differential pressure as inflatable elements, are sensitive to hole size [5].

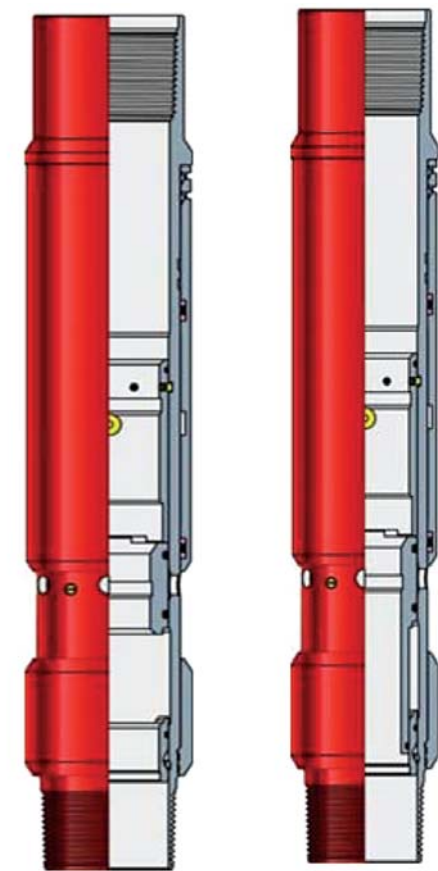

Type P ES-II* Cementer
 * Plug operated, external sleeve
 ** Hydraulic operated, external sleeve

Figure 12. Two-stage cement tools [5]



Figure 13. The external sleeve inflatable packer collar [4]

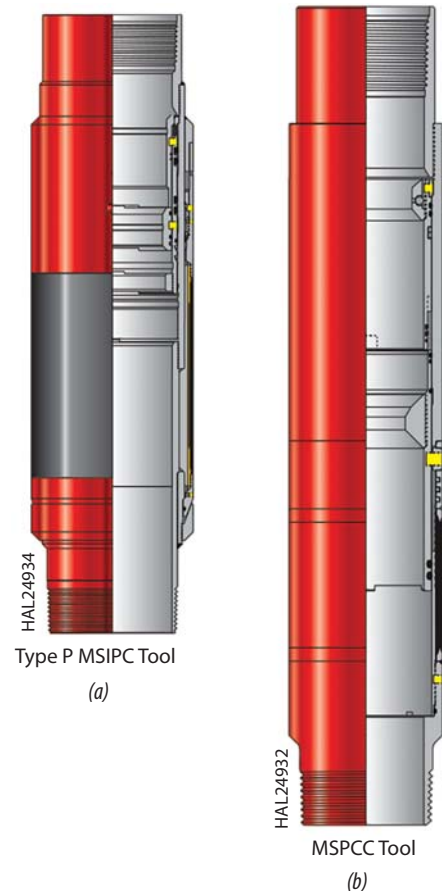

Figure 14. The plug-operated multi-stage inflatable packer collar (a) multi-stage packer cementing collar (b)[5]

4.3. Swell packer

Swell packers can be considered to use in Dai Hung wells as back-up zone isolation in case of poor cement bond. Swell packers can also provide extra sealing capability/redundant seal to prevent a micro-annulus or mud channel when the packers are cemented in. The placements of swell packers are designed to place above the top of cement or between zones of interest to avoid cross-flow or communication between zones.

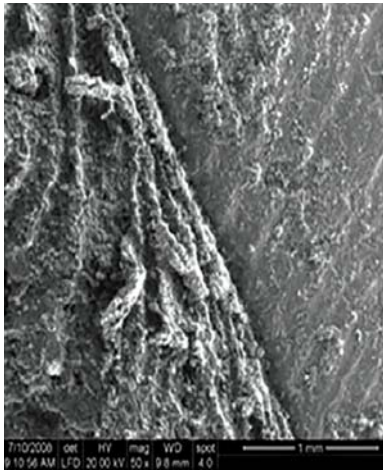

Figure 15. Cement/rubber interface

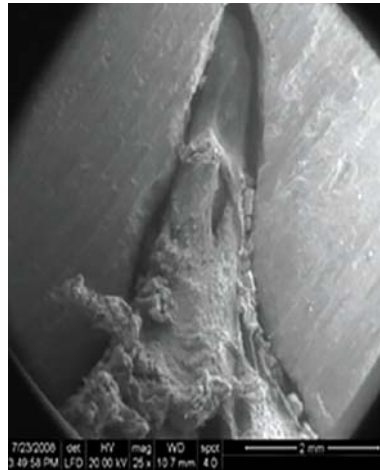

Figure 16. Rubber swelling into crack

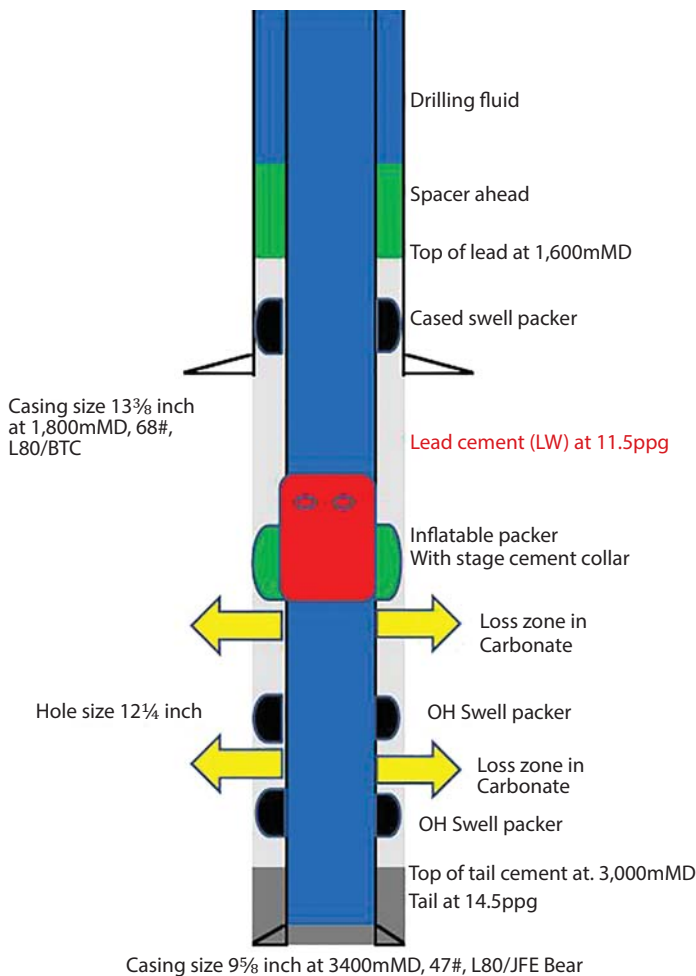

Figure 17. Schematic with new cement system and tools for Dai Hung field [6]

5. Conclusions

Based on laboratory testing and field application results, the light weight cement slurry has proved to meet the technical requirements for cementing across the fractured carbonate zones with the partial loss condition in Dai Hung field. The 9⁵/₈ inch casing can be cemented with a low cement density but this cement slurry still provides the same compressive strength as the conventional cement slurry for ensuring zone isolation. Also, this light weight cement is to help in the bridging top of cement to the designed depth.

The successful solution to improve the cement bond quality for 9⁵/₈ inch casing with lost circulation issue must combine one or several technologies. The schematic in Figure 17 would provide a clearer view of this combined solution including lightweight cement, special cement spacer, a two-stage cementing tool integrated with an inflatable packer and swell packers. The engineer would need to design and propose a suitable cement system/tools basing on the conditions of each well in Dai Hung field.

References

1. Le Vu Quan. *Cement bond improvement study for carbonates zone in Dai Hung field, Block 05-1a, offshore Vietnam*. Vietnam Petroleum Institute. 2016.
2. Tam Nguyen, Makabe, Do Huu Trung. *DHN-1X, 9⁵/₈" casing tuned light cement proposal*. Halliburton International Inc. 2015.
3. Waqas Mushtaq. *Experimental study of cement-formation bonding*. Norwegian University of Science and Technology. 2013.
4. Halliburton International Inc. *External sleeve inflatable packer collar (ESIPC™) cementer*. www.halliburton.com.
5. Halliburton International Inc. *Multiple-stage cementing equipment*. www.halliburton.com.
6. Tran The Hung, Do Huu Trung. *2nd stage cementing equipment & swell packer proposal*. Energy Uncovered. 2015.

RESERVOIR MODEL AND APPLICATION OF SEISMIC ATTRIBUTES TO PREDICT LOWER MIOCENE B10 SANDSTONE RESERVOIR DISTRIBUTION IN SU TU DEN OIL FIELD, BLOCK 15-1, CUU LONG BASIN

Nguyen Tien Thinh¹, Nguyen Tuan Anh¹
 Hoang Quang Trung¹, Diem Dang Thuat¹, Cao Le Duy²
¹Vietnam Petroleum Institute
²Cuu Long Joint Operating Company
 Email: thinhnt@vpi.pvn.vn

Summary

A clear understanding of the geological model and distribution of a reservoir is very critical for better production approaches. Precisely determining the geological concept is an initial step to orientate reservoir study. The combination of geological model with the results of seismic attribute analysis is the key to determine reservoir distribution. This paper addresses a detailed analysis of regressive delta fan facies of Lower Miocene B10 reservoir which have been investigated by integrating core description, biostratigraphy, well log patterns, seismic characteristic, and seismic attributes.

Key words: Facies, depositional environment, mouth bar, distributary channel, seismic attributes, seismic inversion.

1. Introduction

B10 sandstone reservoir in Su Tu Den oil field is one of the most prolific Lower Miocene reservoirs with excellent properties. Located in Block 15-1, Cuu Long basin, offshore southern Vietnam, Su Tu Den oil field is about 120 miles (180km) to the south-east of Ho Chi Minh City. To date, hydrocarbons have been discovered in several reservoirs of Su Tu Den oil field. In this field, the main produced commercial reservoir is fractured basement. Additional commercial hydrocarbon also has been produced from the Lower Miocene and Oligocene "C". Some minor

hydrocarbon presences were found in the Oligocene "D" and "E" sequences at Su Tu Den oil field, but not yet in sufficient quantities to merit development.

The oil bearing arkose B10 sandstone reservoir is the main clastic reservoir that has been producing since 2003. This reservoir varies from 10 - 12m in thickness with a depth range from 1,700m to 1,740m TVDSS (true vertical depth subsea). Closing contour covers the area of around 14km². The cumulative production (in 2015) is 73MMstb with a total of 14 active production wells. Characterised by high porosity (28% on average),

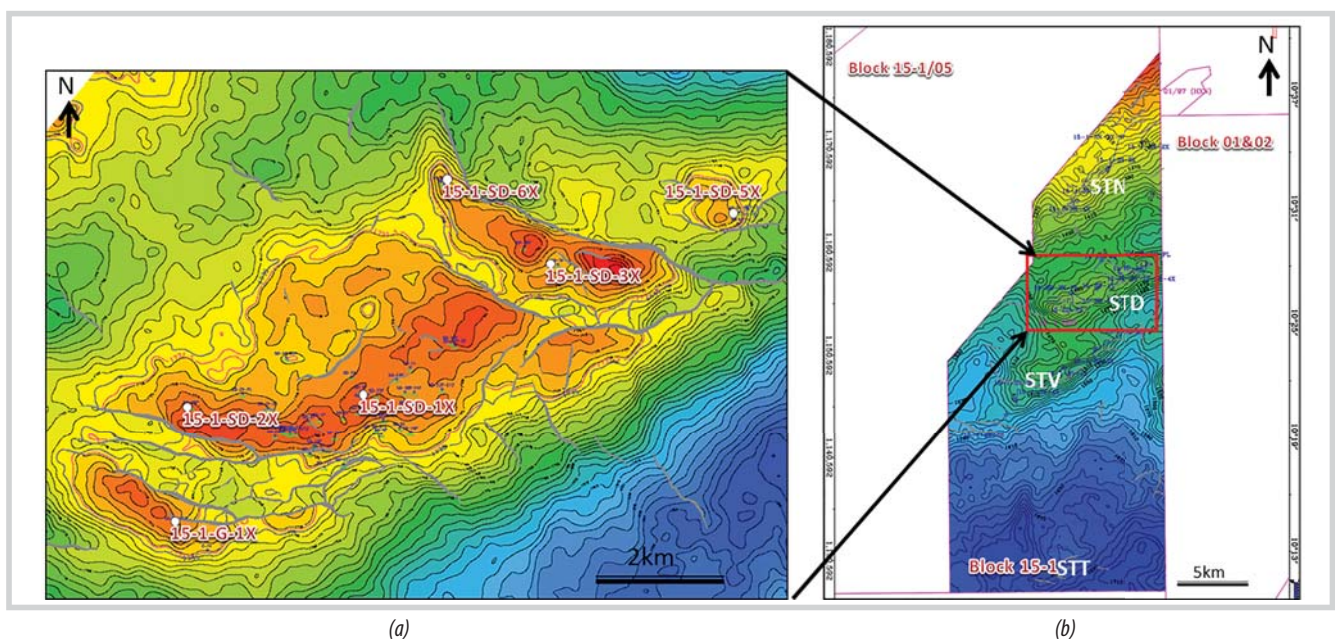

Figure 1. Time structure map of B10 highlighted by exploration wells (a) and the location of Su Tu Den field in Block 15-1 (b)

permeability (> 2,200mD), and low residual fluid (36%), the B10 sandstone reservoir is considered one of the best quality clastic reservoir in Cuu Long basin. Understanding the geological model and its distribution is a key for increasing production efficiency. This paper will address an integration of seismic characteristics, seismic attributes with a geological model to predict the sand-body distribution of the B10 reservoir in Su Tu Den field, Block 15-1, Cuu Long basin.

2. Database and methodology

The seismic data used is PSDM Kirchhoff re-processed in 2002 covering an area of 337km² and 6 exploration wells with sufficient data, including biostratigraphy results (analysed by VPI labs) for study (Figure 1).

Cores have been taken from two wells with detailed description of the lithofacies and depositional environment (described by ConocoPhillips) for calibration with well-log pattern analysis. High resolution biostratigraphic analysis provides calibration of both depositional systems and specific depositional environment based on foraminiferal analysis and palynological-palynofacies analysis. The consistent combination of that information would lead to a reasonable depositional model. The workflow for the work is presented in Figure 2.

3. Geological model

The initial geological model was constructed based on integrated core description and high resolution biostratigraphy data. The interpretation results of

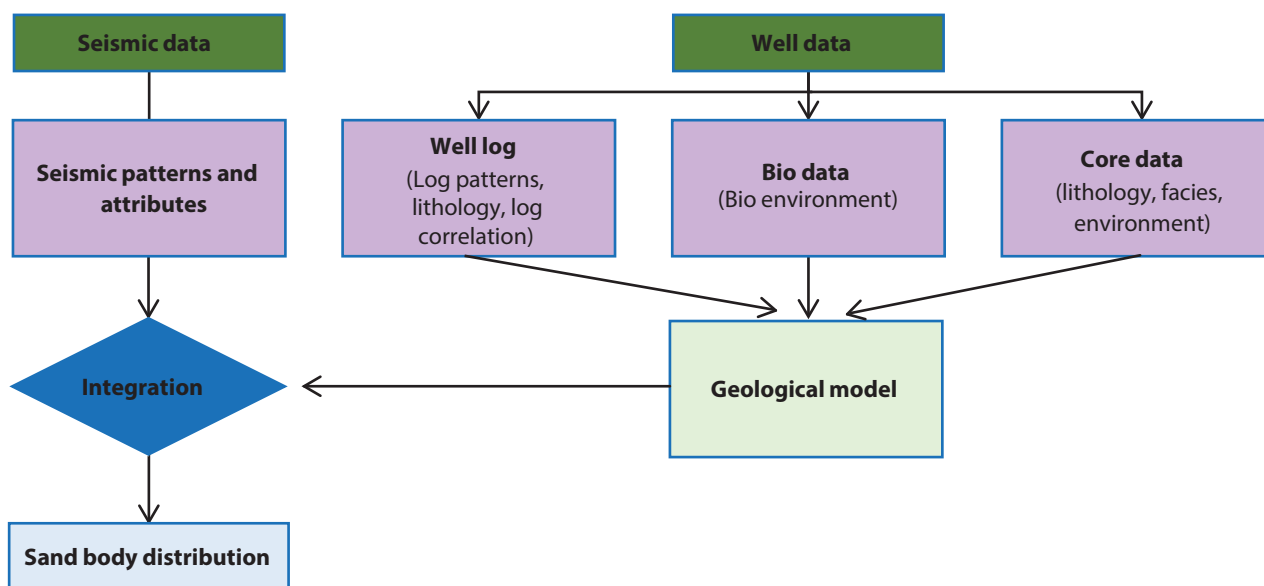

Figure 2. Workflow chart for the study

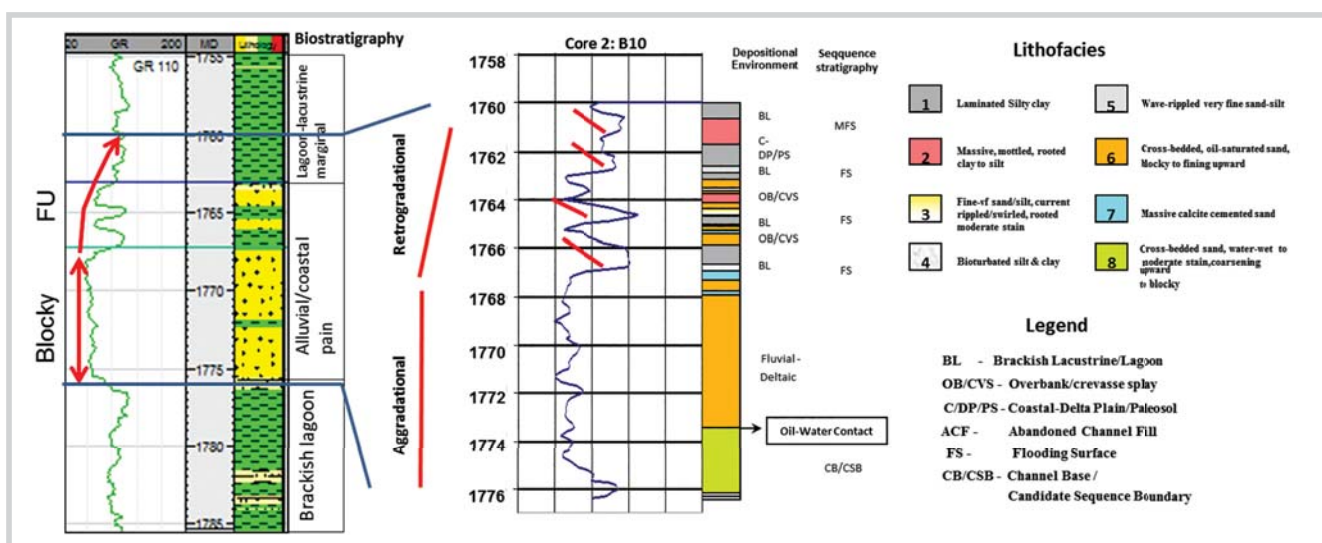

Figure 3. Calibration of core to log patterns showing the facies of mouth bar at the base and distributary channel toward the top

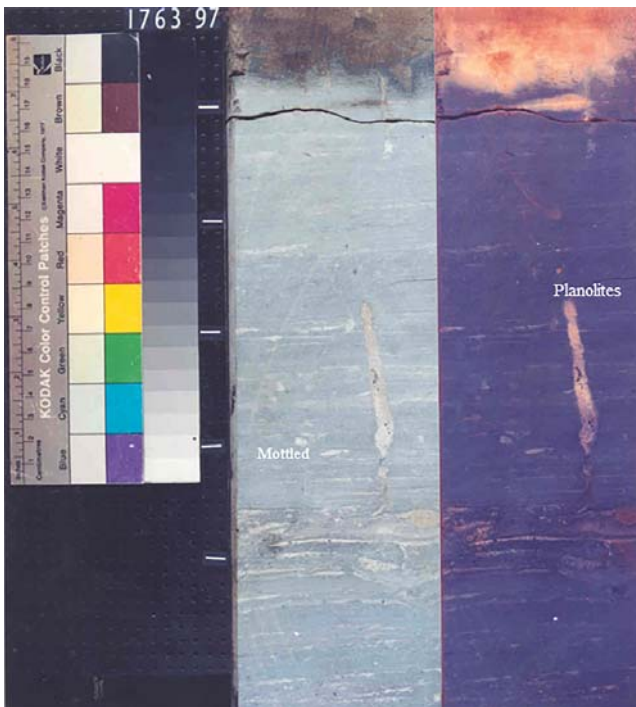

Figure 4. Lithofacies 1, laminated silty clay, mottled interpreted as lacustrine to brackish-marine deposits. Bioturbation in this facies is sparse to absent and typically consists of *Planolites* sp. Forms. Most sedimentary structures comprise streaky to lenticular low angle silt laminae, indicating an overall low energy setting. The vertical scale is 1 foot (0.33m).

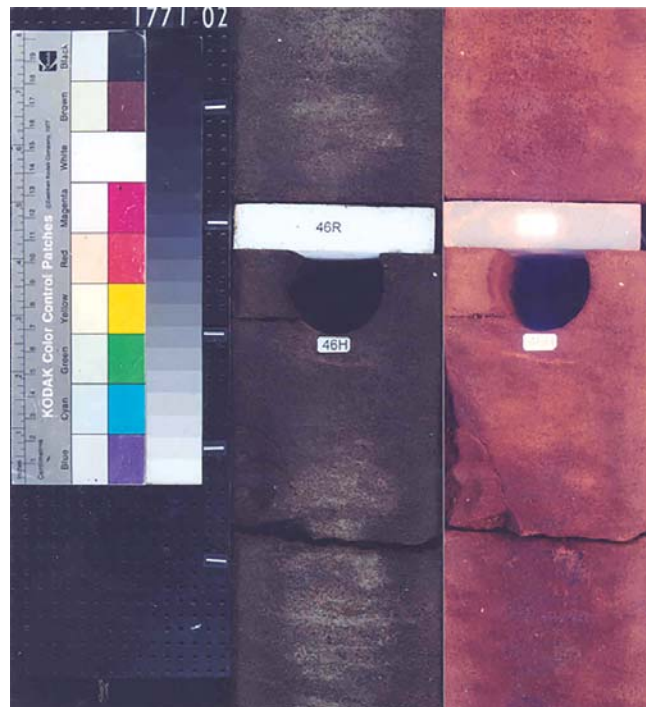
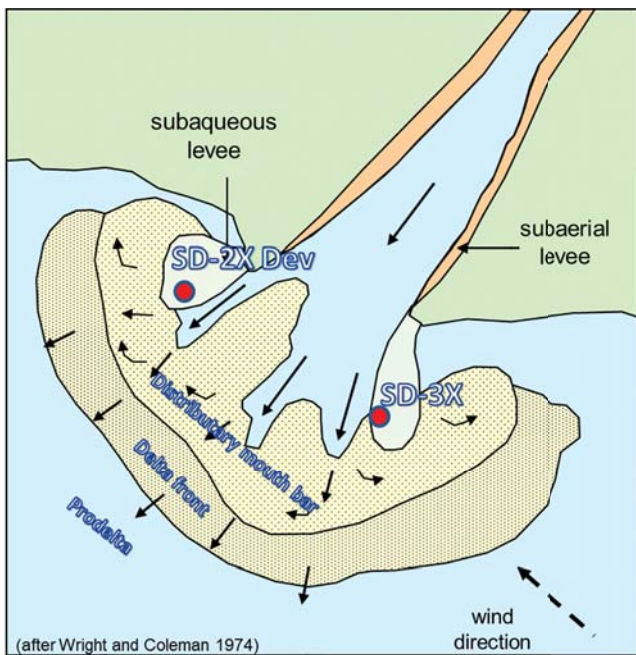
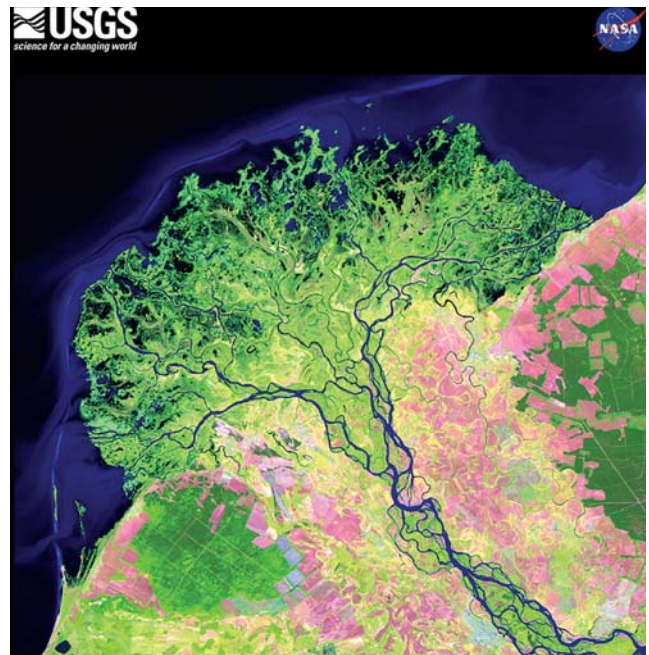

Figure 5. Lithofacies 6, oil stained, massive to low angle laminated and cross-bedded sand. Grain size ranges from lower coarse to lower fine. Part of a blocky aggradational to fining upward succession. Interpreted as deposits of distributary mouth bar, distributary and fluvial channels. The vertical scale is 1 foot (0.33m).



(a)



(b)

Figure 6. Schematic of B10 depositional setting with relative location of two taken cores (a) and a partial satellite paleogeographic analog of modern Selenge River delta-North Mongolia (b)

depositional environments and sequence stratigraphy from core data were based on observed lithology, grain size, sedimentary structures, laminae geometries, and bioturbation styles. B10 reservoir succession was described as an aggradational stack of cross-bedded and low angle laminated sands deposited in fluvial dominated

delta in the lower part and distributary channel in the upper part [1, 2] (Figure 3).

Analysis of foraminifera and palynological assemblages from wells of B10 zone in Su Tu Den field reflects a slow transgression progress from bottom to top. This slow transition occurred from alluvial plain/

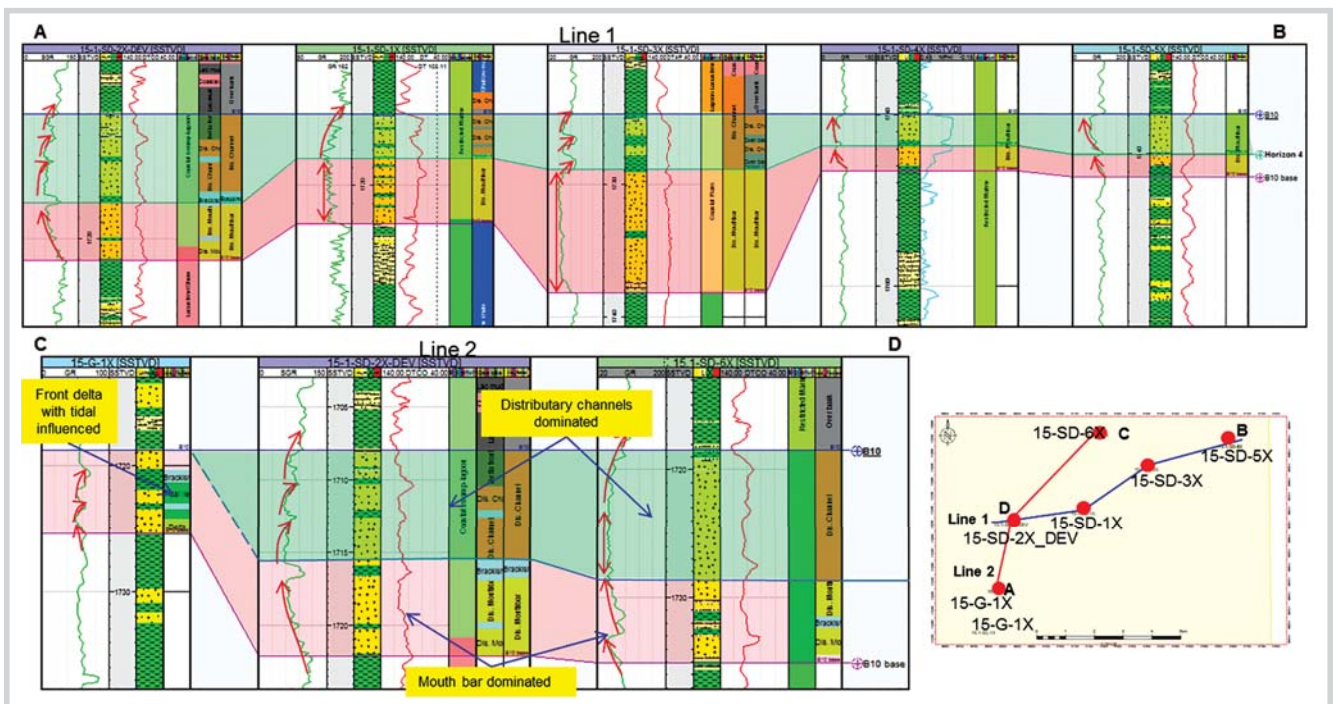

Figure 7. Well log correlations in the main pool of Su Tu Den area showing the two different section of B10 sand with dominant mouth bar in the lower part and the distributary channels in the upper part

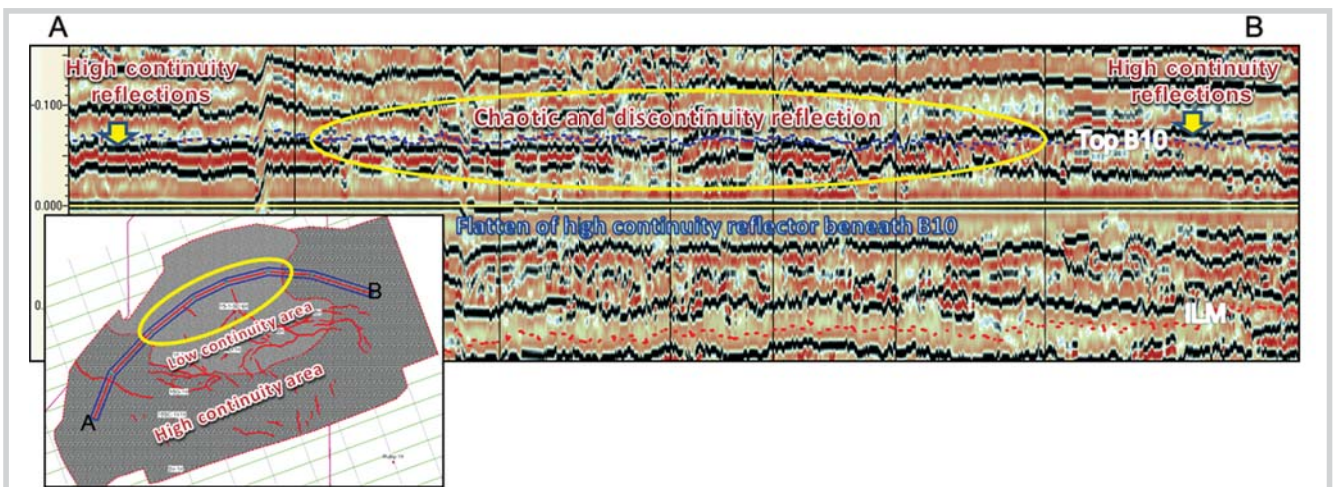

Figure 8. Flattened paraphrase seismic showing low and high continuity implies a different depositional environment of B10. The index map showed a spatial distribution of continuity reflection zones

channels to freshwater lagoon/lacustrine with brackish influence [3 - 6]. The depositional environment derived from biostratigraphy data totally agrees with the core description (Figures 4 and 5) [2] that helps interpreter determine the geological model concept (Figure 6).

Calibration of the core, biostratigraphy data to the well-log patterns is the next step for facies and environment interpretation for the entire wells. Core to log pattern calibration in Figure 3 of SD-3X shows the mouth bar facies featured by a blocky profile with slightly coarsening upward trend; while fining upward succession (bell shape)

reflects distributary channels. Generally, a regression environment of B10 distinctively could be divided into 2 parts: 1) more dominance of mouth bar facies in the lower section and 2) series of stacked distributary channels in the upper section (Figure 7).

4. Analysis of seismic characteristics and seismic attributes

Seismic data takes an important role in defining spatial distribution. Seismic facies analysis is based on seismic reflection to separate the areas of different seismic responses that possibly could imply different depositional

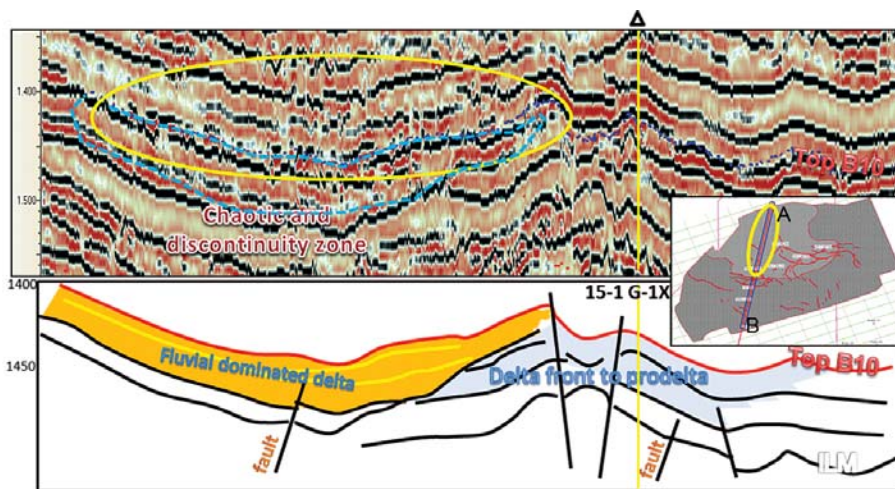

Figure 9. Paraphrase seismic showing depositional environment of B10 (upper) and a cartoon representing related environment (lower)

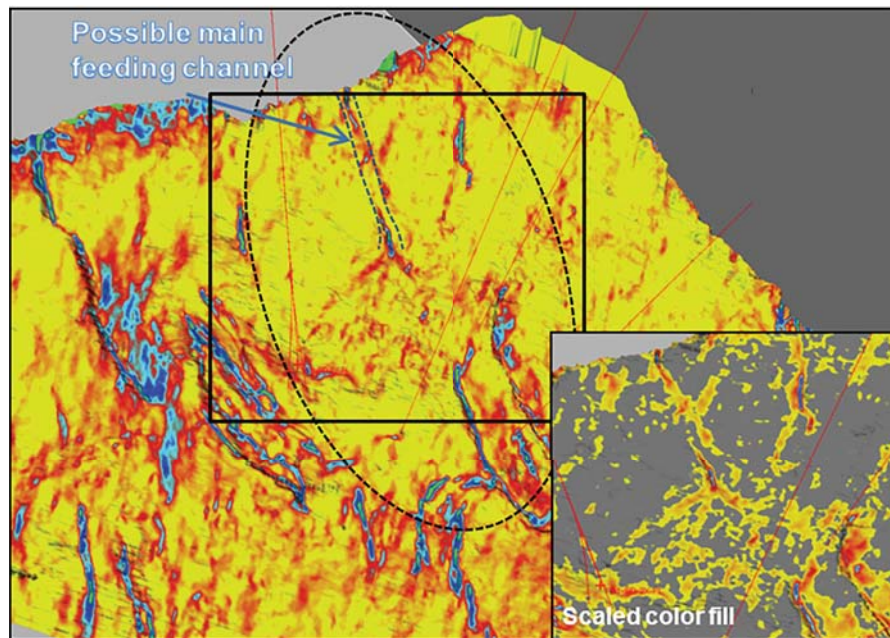

Figure 10. Extracted map from discontinuity cube with a window (B10 0/+30ms) showing a fan shape delta

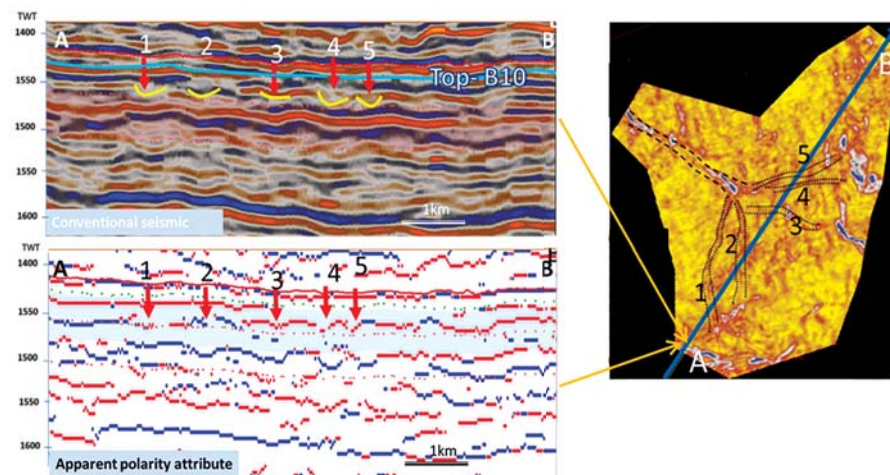

Figure 11. Possible distributary channels in apparent polarity attribute (lower section) and their position in fan delta (top right) compared with modern analogy (bottom right)

environments. Using paraphrase attribute - instantaneous phase with the background component removed, the seismic section with chaotic and discontinuity features probably indicates the domination of fluvial environment meanwhile conformable and continuous reflection could be considered as an indicator for marine influenced areas (Figure 8). Figure 9, North-South seismic line, crossing well 15-1-G-1X, shows the separation between the chaotic and discontinuity area (the yellow eclipse) and the area of conformable and more continuous reflection, implying differently influenced environment as discussed previously.

A seismic attribute is a quantitative measure of a seismic characteristic. Analysis of attributes has been integral to reflection seismic interpretation since the 1930s. There are now more than fifty distinct seismic attributes calculated from seismic data and applied to the interpretation of geological structure, stratigraphy and rock/pore fluid properties [7]. The study and interpretation of attributes provide us with some qualitative information of the geometry and physical parameters of the subsurface [8]. In this paper, we present some of the valuable seismic attributes as inputs for reservoir distribution prediction. An amplitude extraction technique has been applied to cover the whole interval of the reservoir to seek for any geological event. As a result, a possible delta fan can be observed in horizon based attribute extraction map from discontinuity cube of B10 reservoir covering the window of 0/+30ms

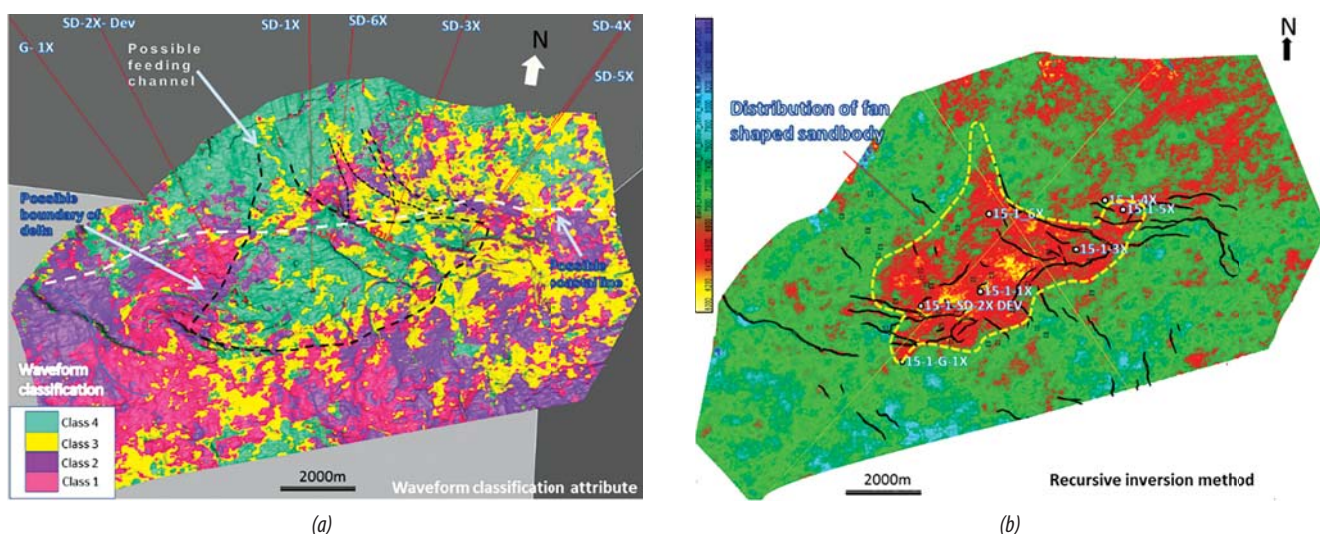

Figure 12. Waveform attribute of B10 (a) and the horizon based (window: 0/+25ms) stochastic inversion extraction (b) showing possible fan delta shape

(Figure 10). A number of possible feeding channels from North-northwest and the distributary channels are visually observed on re-scaled colour fill. On section view, these distributary channels possibly can also be seen on conventional seismic and apparent polarity attribute section (Figure 11). The waveform classification method [9] (Figure 12) - modern techniques that make it possible to define and map subtle changes in seismic response also provide very clearly the similar fan delta shape which is difficult to observe on conventional seismic. Integration of depositional facies derived from the well log with seismic attributes will lead to the prediction of B10 sand-body spatially. A useful additional extraction with a window of 0/+25ms from seismic inversion [10] clearly illustrates the area extent of fan delta/sand-body.

5. Conclusions

Understanding geological model and its reservoir distribution is the main goal of any geologist when characterising the reservoir. Using different seismic attributes with agreeable calibration to the geological model constructed from direct data provides excellent information to determine the spatial distribution of a reservoir since it is not easy to observe on conventional seismic. In this study, we have integrated different disciplines to determine the facies of B10 reservoir that was deposited as a regressive delta fan and its possible distribution. This result may provide very useful information for 3D geological modelling for better producing approach.

References

1. ConocoPhillips. *Depositional environments and sequence stratigraphy of Miocene cores from the SD2X appraisal well Cuu Long basin, Vietnam*. 2001.
2. ConocoPhillips. *Depositional environments and sequence stratigraphy of Miocene cores from the SD-3X appraisal well Cuu Long basin, Vietnam*. 2002.
3. Vietnam Petroleum Institute. *Biostratigraphical report 15-1-SD-2X well*. 2001.
4. Vietnam Petroleum Institute. *Biostratigraphical report 15-1-SD-3X well*. 2001.
5. Vietnam Petroleum Institute. *High resolution biostratigraphy report, 15-1X,-SD-6*. 2007.
6. Vietnam Petroleum Institute. *High resolution biostratigraphy of the Early Miocene interval 1,690 - 1,870m of the 15-1-SD-4X well, Cuu Long basin, offshore Vietnam*. 2002.
7. M.T.Taner, F.Koehler, R.E.Sheriff. *Complex seismic trace analysis*. Geophysics 1979; 44(6): p. 1041 - 1063.
8. Satinder Chopra, Kurt J.Marfurt. *Seismic attributes - A historical perspective*. Geophysics. 2005; 70(5): p. 3 - 28.
9. A.Eric, B.John. *Seismic waveform classification: Techniques and benefits*. CSEG Recorder. 2004; 29(3).
10. A.Haas, O.Dubrulle. *Geostatistical inversion - a sequential method of stochastic reservoir modeling constrained by seismic data*. First Break. 1994; 12(11): p. 561 - 569.

INTERWELL TRACER METHOD USING PARTITIONING COMPOUNDS NATURALLY EXISTING IN CRUDE OIL FOR DETERMINATION OF RESIDUAL OIL SATURATION

To Ba Cuong¹, Nguyen Hong Phan², Nguyen Huu Quang¹

¹Centre for Applications of Nuclear Technique in Industry (CANTI), Vietnam Atomic Energy Institute

²Institute of Mechanics, Vietnam Academy of Science and Technology (VAST)

Email: cuongtb@canti.vn

Summary

Beside the interwell tracer method in which the artificial tracers are injected into the reservoir, the method of using partitioning organic compounds in crude oil components such as alkylphenols and aliphatic acids as the Natural Partitioning Interwell Tracers (NPITs) to determine residual oil saturation (S_{or}) has drawn attention as a potential complementary method. Owing to the solubility into both oil and water phases, the concentration of NPITs in oil and also in produced water decreases along water injection time. Based on the similarity with chromatographic retardation principle used in the artificial interwell tracer method, residual oil saturation in the swept area between well pair can be determined by mean transit time from the concentration curve of NPITs analysed in produced water and partitioning coefficients K_d measured in the laboratory.

The paper presents the results of using NPITs to calculate S_{or} based on the data simulated by the UTCHEM simulator on the models of five-spot and direct-line. The results showed that the pairs of compound having partitioning coefficients K_d in range up to 3.0 can be used to estimate S_{or} in the injection stage from 1 to 3 pore volumes (PV) with 5% deviation from the S_{or} value given by the model. The paper also discusses the limitations of the proposed NPIT method that need to be improved and solved in future researches.

Key words: Natural partitioning interwell tracer (NPIT), partitioning coefficient, residual oil saturation, numerical simulator.

1. Introduction

Beside the conventional interwell tracer method in which the artificial tracers are injected into the reservoir, the method of using partitioning organic compounds existing in crude oil such as alkylphenols and aliphatic acids as the Natural Partitioning Interwell Tracers (NPITs) to determine residual oil saturation (S_{or}) has drawn attention as the potential complementary method [1, 2].

Alkylphenols and aliphatic acids, the organic compounds existing in crude oil, are soluble in both oil phase and water phase in which the distribution of its concentrations between phases is defined by its partitioning coefficient K_d [3, 4]. During water injection, those compounds gradually dissolve into water phase under concentration equilibrium condition that causes reduction of their concentration in both oil phase and water phase. Akasawa and Sinha [1, 2] have proven that the concentration curves of those partitioning compounds obtained by analysis of produced water can be converted into the similar form of injected interwell tracer curves.

By applying the chromatographic retardation principle of partitioning solutes moving in mobile phase (water) in contact with immobile phase (residual oil), the residual oil saturation can be determined based on the retardation in transit time of a pair of NPITs and their partitioning coefficients K_d measured in the laboratory under reservoir condition.

This paper presents the preliminary results of using the chromatographic retardation principle to calculate S_{or} based on the data simulated by the UTCHEM simulator on the models of five-spot and direct-line.

2. Mathematical equations using NPITs for S_{or} calculation

Suppose the formation contains 2 phases, oil and water, the advection, dispersion and exchange transport of compound k between phases is given by the equation:

$$\varphi \frac{\partial C_k}{\partial t} + \nabla \vec{N}_k = 0 \quad (1)$$

Where C_k is the concentration of compound in the phases, which is described as:

$$C_k = \sum_{p=1}^{n_p} S_p C_{kp} \quad (2)$$

and N_k is a flux of compound k including advection and dispersion:

$$\vec{N}_k = \sum_{p=1}^{n_p} \left(C_{kp} \vec{u}_p - \varphi S_p \vec{K}_{kp} \cdot \nabla C_{kp} \right) \quad (3)$$

In which, $n_p = 2$: number of phases; S_p : saturation of phase p ; C_{kp} : concentration of compound k in phase p ; \vec{K}_{kp} : dispersion tensor of compound k in phase p ; \vec{u}_p : velocity of phase p and t : time.

The initial and boundary conditions are as follows:

$$\begin{cases} C_{kp} |_{injector} = 0 & t > 0 \\ C_{kp} = C_{kpl} & t = 0 \\ C_{kp} = 0 & t \rightarrow \infty \end{cases} \quad (4)$$

Where C_{kpl} is the initial concentration of compound k in phase p in formation.

Equation (1) can be solved with the following assumptions: the phasic concentration equilibrium of compound k is instantaneously achieved while oil/water contacting; the partitioning coefficient is constant; no mass transfer of compounds on the boundary of studied zone except boundaries of injection well and production well; at the boundaries of injection well and production well, the diffusion effect is ignored due to the high velocity of water; the degradation, absorption and interaction of compounds are not considered. Equation (1) is then rewritten as below:

$$\begin{aligned} & \sum_{p=1}^{n_p} K_{dkp} \iiint (\varphi S_p (C_{kw} - C_{kwl})) dV_R \\ & + \sum_{wells} \left(q \sum_{p=1}^{n_p} K_{dkp} \int_0^t f_p (C_{kw} - C_{kwl}) d\tau \right) = 0 \end{aligned} \quad (5)$$

Where, $K_{dkp} = C_{kp}/C_{kw}$ is the partitioning coefficient of compound k , equal to the ratio of compound concentration in phase p to that in water; C_{kwl} is the initial concentration of compound k in formation water; f_p is fraction of phase p in fluids at production well and q is total production flow.

Equation (5) shows that, if partitioning coefficient K_{dkp} of compound k is measured in laboratory, the saturation of phase p (S_p) in the swept area by water can be calculated by analysis of concentration C_{kw} of the compound in produced water collected at the production well.

Due to $K_{dkw} = C_{kw}/C_{kw} = 1$; f_p at injector = 1; $q_{inj} = -q_{prod}$, equation (5) is converted to:

$$\sum_{p=1}^{n_p} K_{dkp} \iiint \left(\varphi S_p \left(\frac{C_{kw} - C_{kwl}}{C_{kwl}} \right) \right) dV_R + q_{prd} m_{OCk} = 0 \quad (6)$$

Where, m_{OCk} is zero-moment of concentration of compound k given by:

$$m_{OCk} = \int_0^t \left(1 + (f_w + K_{dkp} f_o) \left(\frac{C_{kw} - C_{kwl}}{C_{kwl}} \right) \right) d\tau \Big|_{producer} \quad (7)$$

The average transit time of the compound k is defined as:

$$\bar{t}_k = \lim_{t \rightarrow \infty} m_{OCk} = \int_0^{\infty} \left(1 + (f_w + K_{dkp} f_o) \left(\frac{C_{kw} - C_{kwl}}{C_{kwl}} \right) \right) d\tau \Big|_{producer} \quad (8)$$

When $t \rightarrow \infty$, the combination of equation (6) with equation (8) gives:

$$V_w + K_{dkp} V_o = q_{pro} \bar{t}_k \quad (9)$$

Equation (9) contains two unknowns, water volume V_w and oil volume V_o , therefore it needs at least 2 compounds with different K_d to calculate oil saturation S_o as shown in equation (10) below.

$$S_o = \frac{V_o}{V_p} = \frac{\bar{t}_2 - \bar{t}_1}{(K_{d2} - 1)\bar{t}_1 - (K_{d1} - 1)\bar{t}_2} \quad (10)$$

Equation (10) was derived by Sinha và Asakawa [1], which is similar to the equation used for artificial partitioning interwell tracer [2]. The NPIT method is of interest to researchers working in the field of environmental study to assess the residues of organic compound contamination in soil.

In this research work, the injection models in five-spot and direct-line forms were created and the transport of naturally partitioning organic compounds was simulated by using UTCHEM simulator to give the concentration of the compounds at the production well. The obtained concentration curves were then exploited to estimate oil saturation by applying equation (10) to assess the feasibility of NPIT method in the practical application.

3. Simulation results

UTCHEM (The University of Texas's Chemical Simulator) is the software for simulating reservoir model with multiphase, multicomponent developed by Texas University. UTCHEM allows simulation of advection, dispersion and exchange of solutes between phases in reservoir media, including the leaching process of oil

Table 1. The partitioning organic compounds used in the models

Partitioning organic compounds	Partitioning coefficient $K_d = \frac{C_o}{C_w}$	Initial concentration in oil (mg/L)	Initial concentration in formation water (mg/L)
Phenol	0.16	1.6	10
4-Methyl Phenol (4MP)	0.58	5.8	10
2-Methyl Phenol (2MP)	0.75	7.5	10
4-Propyl Phenol (4PP)	1.34	13.4	10
3,4-Dimethyl Phenol (34DMP)	1.61	16.1	10
2,4-Dimethyl Phenol (24DMP)	3.09	30.9	10
4-Ethyl Phenol (4EP)	7.37	73.7	10

organic components from oil phase to water phase during oil production [6].

UTCHEM was used to run with two water injection models: the quarter five-spot pattern, which is a common model in stratified sediment reservoir; and the direct-line pattern, which is typical model in edge water injection or gravity injection. The models describe 3-D reservoir having initial oil saturation (S_{oi}) of 0.65 and residual oil saturation (S_{or}) of 0.35. The quarter five-spot model has the size of 165 x 165 x 12m divided into 55 x 55 x 4 grid cells and the direct-line model has the size of 200 x 100 x 8m divided into 25 x 50 x 4 cells in corresponding ratio of length to width $d/a = 2$.

The general parameters of the models are:

- Porosity $\phi = 0.2$; water viscosity $\mu_w = 0.7\text{cp}$; oil viscosity $\mu_o = 4\text{cp}$;
- Longitudinal and transversal dispersion coefficients are $\alpha_{DL} = 0.03\text{m}$ and $\alpha_{DT} = 0.003\text{m}$, respectively.
- Phasic permeability curve is described in accordance with Corey, with critical water saturation $S_{cwr} = 0.3$; $S_{or} = 0.35$; water endpoint: 0.15; oil endpoint: 0.85; water exponent: 1.5; oil exponent: 2; end point mobility ratio = 1.

The initial concentration and partitioning coefficient of the partitioning organic compounds in

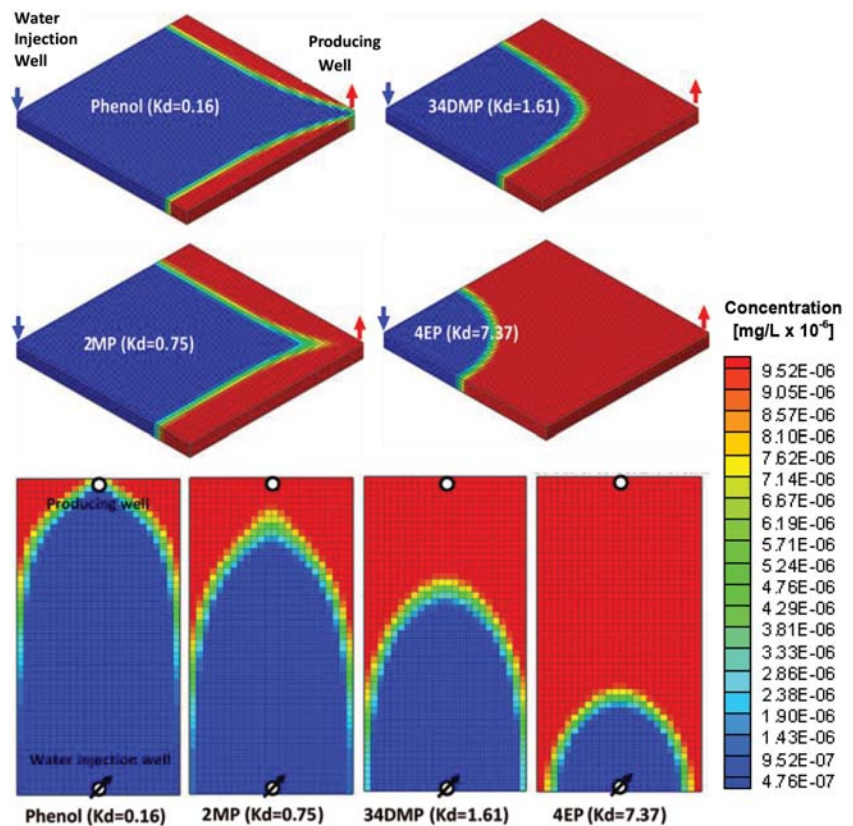

Figure 1. Concentration distribution of phenol, 2MP, 34DMP and 4EP in five-spot (top) and direct-line (bottom) at 0.6PV

crude oil referred to in the experimental data of Tracer Lab of CANTI are listed in Table 1. All compounds are supposed to have the same density, alkane number and chemical properties but different partitioning coefficients.

Water injection last till 5 pore volumes (PV) of model in order to recover most of the compounds in producer. Concentration of the compounds was supposed to instantaneously achieve equilibrium between oil and water during water injection. Figure 1 illustrates concentration distribution in the model at 0.6PV stage of water injection. Figures 2 and 3 show the concentration curves of the compounds in water and oil obtained at the producer. Figure 4 and 5 introduces the calculated results of oil saturation S_o in accordance with equation (10), whereas average transit time is calculated from equation (8).

Figures 2 and 3 show the concentrations of NPITs in oil phase and water phase are reduced with time, in which the greater K_d the slower reduction

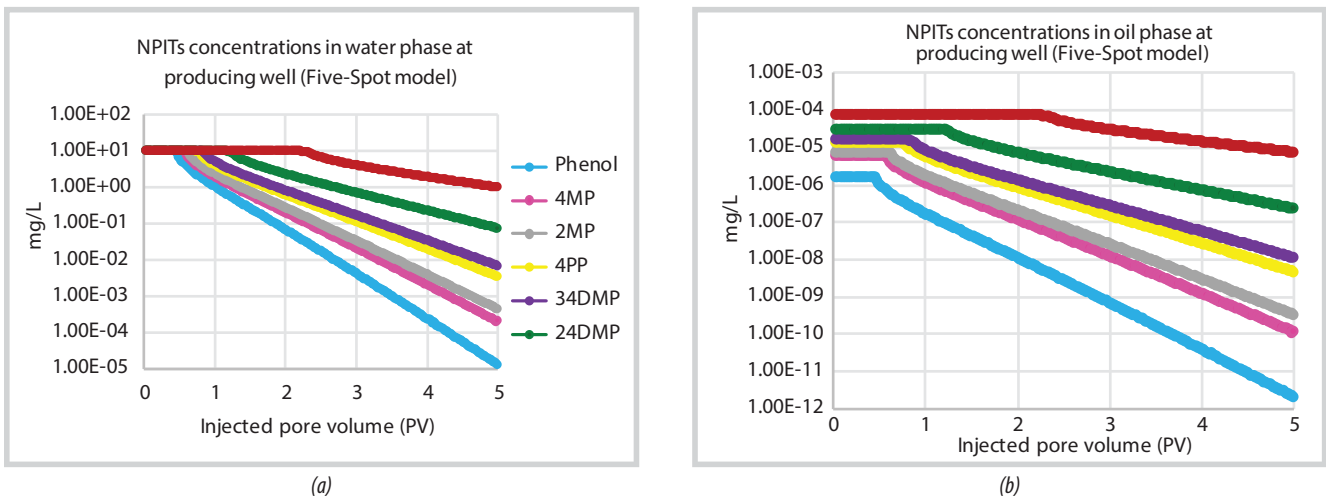

Figure 2. Concentration curves of NPITs in water phase (a) and oil phase (b) at the production well in Five-spot model

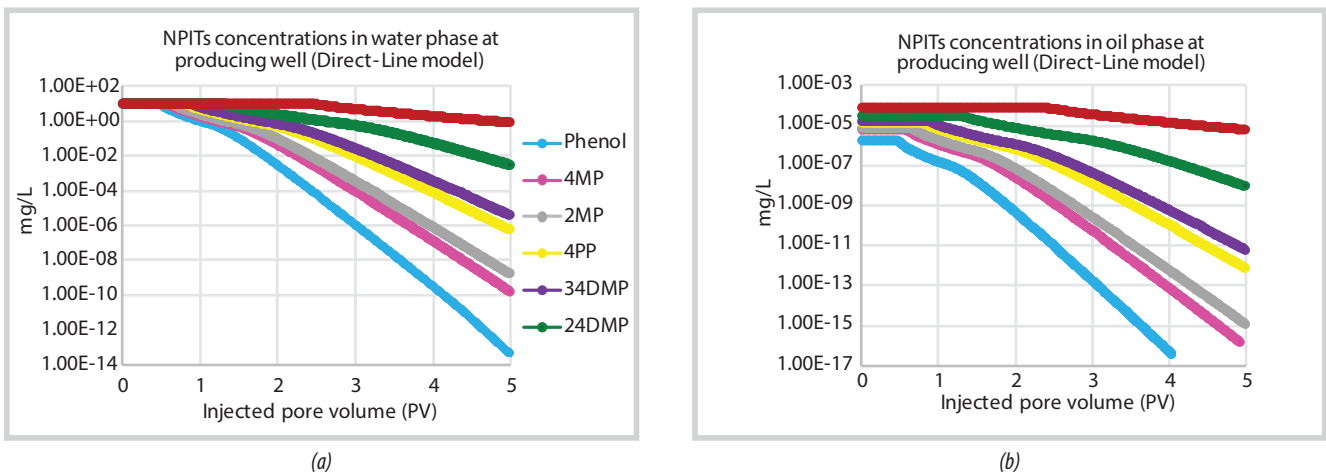

Figure 3. Concentration curves of NPITs in water phase (a) and oil phase (b) at the production well in direct-line model

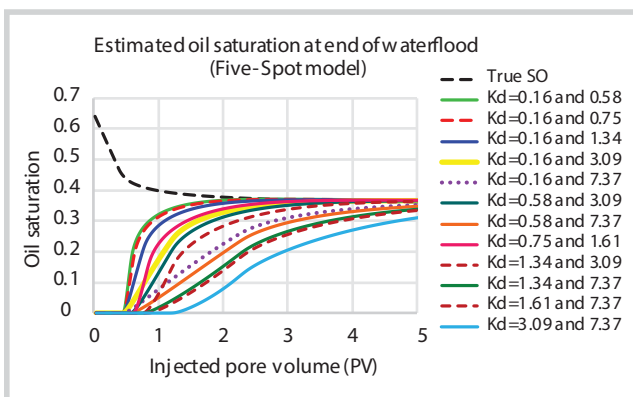

Figure 4. Values of S_{or} calculated from equation (10) by using the pairs of NPITs at different accumulated injection volume in five-spot model

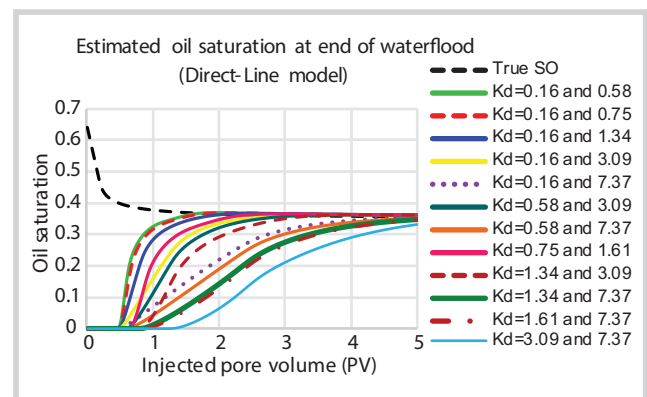

Figure 5. Values of S_{or} calculated from equation (10) by using the pairs of NPITs at different accumulated injection volume in direct-line model

rate. In Figures 4 and 5, the values of S_{or} calculated from equation (10) using the different pairs of compounds are being asymptotic to the value of model. The different pairs give different asymptotic time. The smaller K_d pair gives the quicker asymptotic time that is helpful to estimate S_{or} at early stage of water injection, while the greater K_d gets later asymptotic time that is suitable to

estimate S_{or} at the later stage of injection. It is possibly recognised from Table 2 that, the pair of compounds NPITs having K_d smaller than 3.0 can be used to calculate S_{or} at deviation to that of model in the range of 5%, when applying at the stage from 1 to 3PV which is common in the practice of water injection.

Table 2. Results of Sor calculation in comparison with Sor from model using NPITs of different K_d

Accumulated injection volume	Five-Spot Model			Direct-Line Model		
	1PV	3PV	5PV	1PV	3PV	5PV
Sor from model	0.38	0.36	0.36	0.37	0.36	0.35
Values of Sor calculated from equation (10) by using the pairs of NPITs at different accumulated injection volume. The relative deviation of calculated Sor to modelled Sor is given in parentheses						
Phenol & 4MP ($K_d = 0.16$ & $K_d = 0.58$)	0.32 (14.1%)	0.37 (1.5%)	0.36 (1.5%)	0.31 (15.1%)	0.37 (2.8%)	0.36 (3.1%)
Phenol & 2MP ($K_d = 0.16$ & $K_d = 0.75$)	0.32 (16.3%)	0.37 (1.5%)	0.36 (1.5%)	0.30 (17.1%)	0.37 (2.8%)	0.36 (3.1%)
Phenol & 4PP ($K_d = 0.16$ & $K_d = 1.34$)	0.28 (25.3%)	0.37 (1.5%)	0.36 (1.5%)	0.28 (24.8%)	0.36 (2.3%)	0.36 (3.1%)
Phenol & 24DMP ($K_d = 0.16$ & $K_d = 3.09$)	0.16 (58.1%)	0.36 (0.1%)	0.36 (1.5%)	0.17 (54.8%)	0.35 (0.6%)	0.36 (2.8%)
Phenol & 4EP ($K_d = 0.16$ & $K_d = 7.37$)	0.07 (81.5%)	0.31 (12.8%)	0.35 (0.6%)	0.07 (80.0%)	0.31 (13.3%)	0.35 (1.0%)
4MP & 24DMP ($K_d = 0.58$ & $K_d = 3.09$)	0.11 (70.6%)	0.36 (0.8%)	0.36 (1.5%)	0.12 (66.2%)	0.35 (2.1%)	0.36 (2.6%)
4MP & 4EP ($K_d = 0.58$ & $K_d = 7.37$)	0.04 (88.8%)	0.30 (16.5%)	0.35 (1.2%)	0.05 (87.1%)	0.29 (17.5%)	0.35 (2.1%)
2MP & 34DMP ($K_d = 0.75$ & $K_d = 1.61$)	0.21 (44.5%)	0.37 (1.3%)	0.36 (1.5%)	0.22 (40.7%)	0.36 (1.0%)	0.36 (3.0%)
4PP & 24DMP ($K_d = 1.34$ & $K_d = 3.09$)	0.04 (89.5%)	0.35 (2.9%)	0.36 (1.5%)	0.06 (84.3%)	0.34 (5.4%)	0.36 (2.2%)
4PP & 4EP ($K_d = 1.34$ & $K_d = 7.37$)	0.01 (97.0%)	0.27 (23.9%)	0.35 (2.5%)	0.02 (95.5%)	0.27 (25.2%)	0.34 (4.5%)
34DMP & 4EP ($K_d = 1.61$ & $K_d = 7.37$)	0.005 (98.7%)	0.26 (26.7%)	0.35 (3.0%)	0.01 (97.5%)	0.26 (27.9%)	0.33 (5.5%)
24DMP & 4EP ($K_d = 3.09$ & $K_d = 7.37$)	0.00 (100.0%)	0.21 (41.8%)	0.33 (7.0%)	0.00 (100%)	0.21 (42.0%)	0.31 (11.9%)

The results also showed that the NPIT method can be applied for the determination of Sor for both five-spot and direct-line modes. However, the error of calculation is a little larger in the direct-line model.

4. Conclusions

The injection models in five-spot and direct-line forms were created and the transport of natural partitioning organic compounds was simulated by using UTCHEM simulator to give the concentration values of the compounds at the production well. From the obtained concentration curves, the NPIT method was then applied to calculate the residual oil saturation based on the principle of chromatographic retardation of the pair of partitioning compounds having different partitioning coefficients. The calculated values of Sor were compared with the values given by the models to assess the feasibility of the NPIT method.

The results showed that the pairs of compounds NPITs having K_d smaller than 3.0 can be used to calculate Sor at deviation to that of model in the range of 5%, when applying at the stage from 1 to 3PV which is common in the practice of water injection.

However, the simulation has not taken into account the effect on the concentration curves from water injection adjustment, reservoir heterogeneity, temperature change and the contribution of water injection from different sources, etc. In addition, the application of the principle of chromatographic retardation was based on the conditions that the concentration curves of NPITs have to be obtained from the beginning time of water breakthrough with the availability of initial concentration from formation water. In fact, this condition is only applicable when the sampling survey commences along with water injection and lasts till water injection accumulation over 1PV.

Anyhow, determination of Sor value in the water-out reservoir is a manifest demand before proceeding to enhanced oil recovery. Low costs and the possibility to deploy the method on a series of production wells are great advantages and further researches should be conducted to improve the method for practical application.

Acknowledgements

This research work has been implemented through Project DTCB 06/14/TTUDKTHN-CN under the grant of the Ministry of Science and Technology (MOST).

References

1. R.Sinha, K.Asakawa, G.A.Pope, K.Sepehmoori. *Simulation of natural and partitioning interwell tracers to calculate saturation and swept volumes in oil reservoirs*. SPE/DOE Symposium on Improved Oil Recovery, Tulsa, Oklahoma. 17 - 21 April, 2004.
2. Kazuhiro Asakawa. *A generalized analysis of partitioning interwell tracer tests*. University of Texas. 2005.
3. Barry Bennett, Bernard F.J.Bowler, Stephen R.Larter. *Determination of C₀-C₃-alkylphenols in crude oils and waters*. Analytical Chemistry. 1996; 68(20): p. 3697 - 3702.
4. B.Bennett, S.R.Larter. *Partition behaviour of alkylphenols in crude oil/brine systems under subsurface conditions*. Geochimica et Cosmochimica Acta. 1997; 61(20): p. 4393 - 4402.
5. O.Huseby, A.Haugan, J.Sagen, J.Muller, B.Bennett, S.Larter, E.S.Kikkinides, A.K.Stubos, F.Yousefian, J.F.Thovert, P.M.Adler. *Transport of organic components from immobile and bypassed oil in porous media*. AIChE Journal. 2003.
6. Center for Petroleum and Geosystems Engineering, The University of Texas. *Reservoir engineering research program: Volume II - Technical documentation for UTCHEM-9.0 - A three-dimensional chemical flood simulator*. 2000.

SIMPLE METHOD TO FABRICATE SUPERHYDROPHOBIC CARBON STEEL SURFACE

Nguyen Thi Phuong Nhung¹, Nguyen Viet Chien², Nguyen Dang Nam¹

Tran Phuong Huy¹, Nguyen Van Kiet¹, Nguyen Van Duy²

¹Petrovietnam University

²International Training Institute for Materials Science (ITIMS)

Email: nhungntp@pvu.edu.vn

Summary

This paper reported a simple method to fabricate superhydrophobic carbon steel surface. For this purpose, steel interfaces were coated by micro-nanostructured zinc. These textured surfaces were chemically treated using methyltrichlorosilane. The resulting surfaces were characterised using scanning electron microscopy (SEM) and energy-dispersive X-ray spectroscopy (EDS), their wetting properties were investigated by static contact angle measurement. It was found that the steel surface displayed superhydrophobicity with water contact angle of $152^\circ \pm 2^\circ$ and low hysteresis.

Key words: Superhydrophobic, Zn electrodeposition, micro and nanostructures.

1. Introduction

Nature offers a large variety of examples of surfaces with amazing wettability properties, like the extreme water repellency, for instance of lotus leaves and butterfly wings. When a rain drop is put in contact with these surfaces, it rolls off and collects the dust particles with it at the same time, this is called a self-cleaning effect. These surfaces are the so-called superhydrophobic surfaces that have been deeply studied and well known, with water contact angle greater than 150° . Many studies demonstrate that these natural superhydrophobic surfaces own the micro and nanotexturation and the low wax-like material [1 - 5].

It is disputable that metal and alloyed materials are potentially used in both industry and life, however, these materials are susceptible to corrosion, particularly in the presence of electrolyte on the surface. As the superhydrophobic surfaces can repel water, the superhydrophobic metal or metal alloyed material surface can be ideal for anticorrosion application [6, 7]. Thus, in recent years, these solid artificial superhydrophobic surfaces have attracted significant attention in fundamental research and industrial fields. To mimic the natural superhydrophobic surface, nowadays, many methods have been developed to achieve the artificial metal superhydrophobic surface from various materials (Al, Cu, Fe, Zn, and stainless steel, etc) [8 - 12]. Overall, these surfaces are obtained through the combination of techniques for creation of surface roughness and low surface energy coating. The methods used for achieving

roughness on surface include bottom-up and top-down approaches, for instance, sol-gel methods, electroless deposition, wet etching, dry etching, chemical vapour deposition, pulsed laser deposition, and hydrothermal technique, etc. The low surface energy material coated on the rough surface commonly used the organic molecules including fluorinated molecules, derivative of silane molecules with $-\text{CH}_3$ or $-\text{CF}_3$ groups by different methods such as deposition technique, self-assembled monolayers [1 - 12].

In this paper, we focus on the fabrication of superhydrophobic steel surface via a simple method. A thin Zn layer was firstly deposited on the surface by facile electrodeposition with two electrodes and further functionalised with methyltrichlorosilane. These techniques are easy to handle and do not require highly-priced specific equipment. The resulting surfaces were characterised using scanning electron microscopy (SEM) and energy-dispersive X-ray spectroscopy (EDS), their wetting properties were investigated by static contact angle measurement.

2. Material and method of experiment

2.1. Material

Methyltrichlorosilane, ethanol, acetone, H_2SO_4 , H_2O_2 , and $\text{Zn}(\text{CH}_3\text{COO})_2$ were obtained from Aldrich. The carbon steel X65 obtained from VINA Tan Phat company has the following surface composition: Fe (98.8%), C (0.12%), Mn (0.69%), Si (0.11%), Cr (0.02%), and Ni (0.01%), etc.

2.2. Preparation of superhydrophobic surface

The steel surfaces were cut to 0.1 x 1 x 0.5cm and used as substrates. These substrates were then polished by sand paper (100, 200, and 600) and subsequently degreased in acetone and ethanol, finally rinsed with distilled water.

The zinc deposition was synthesised on steel substrates by electrodeposition method. The two-electrode cells were used in which the cathode electrode was a steel substrate and the anode electrode was a Zn metal sheet (10 x 10mm). As an electrolyte, the mixture of 0.1M $\text{Zn}(\text{CH}_3\text{COO})_2$ and 0.1M NaCl solutions were dissolved in deionised water. A constant voltage of 1V was applied between two electrodes to grow Zn layer during 1,000 seconds. After electrolysis, the substrate was dried and annealed in a furnace at 250°C for 120 minutes.

The Zn coated steel substrates were UV/O₃ treated for 30 minutes to remove any organic contaminant and to generate surface hydroxyl -OH groups. The activated surface was further directly dipped into a solution containing 10wt% methyltrichlorosilane in ethanol for 12 hours. The resulting surface was rinsed in ethanol three times and then dried under a gentle nitrogen flow.

2.3. Surface analyses

Morphology and composition of the thin film were characterised by scanning electron microscope with X-ray microanalysis (SEM, JEOL 7600F with EDS, Oxford instruments). The wetting properties of all substrates were performed by measuring water static contact angle (CA) with OCA - data physics at three positions on each surface using 5 μL distilled water.

3. Results and discussion

3.1. Morphology and elemental composition

Figure 1 presents the SEM images and wettability of Zn coated steel substrates with 1,000 seconds of deposition. The thickness of Zn deposition on the surface was calculated by Alpha - Step U (KLA Tencor). Corresponding with 1,000 seconds of zinc deposition, the zinc thickness was 5.5 μm . It is apparent that the morphology of the coated substrate was changed with Zn deposition. In addition, the steel interface without zinc deposition had the same form structure with zinc coated interface and the zinc film was built on the wall of structure on steel interface, it is also noted that the obtained zinc structures were similar to the structure of pure zinc in the report of Brassard et al. [13]. It is evident that all surfaces had

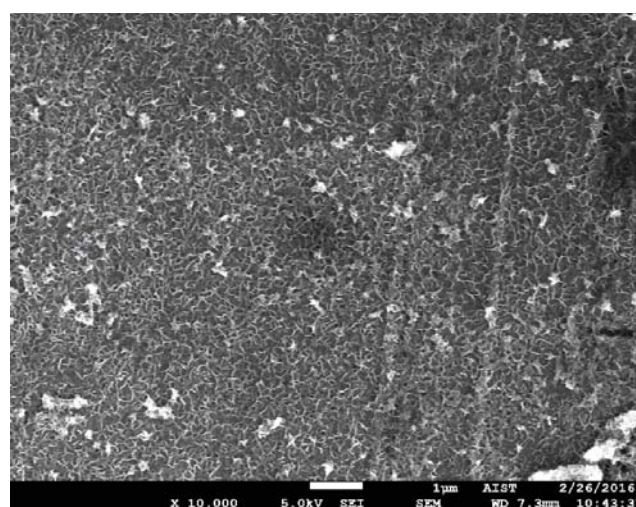

(a) Steel surface

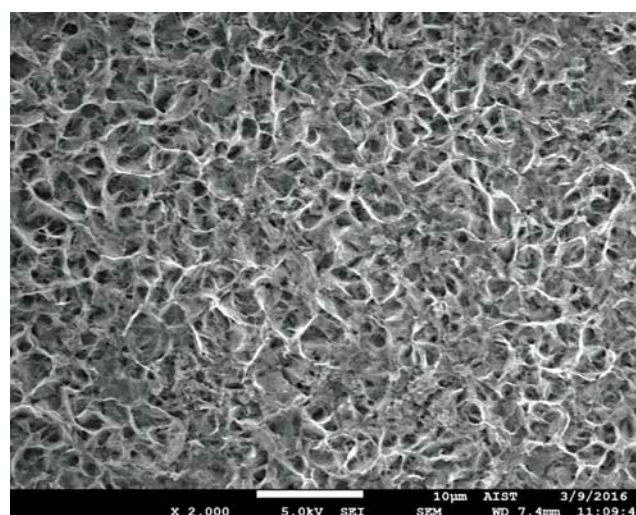

(b) Steel surface with 5.5 μm Zn

Figure 1. The SEM images: steel surface (a) and Zn coated steel surface with silanisation (b)

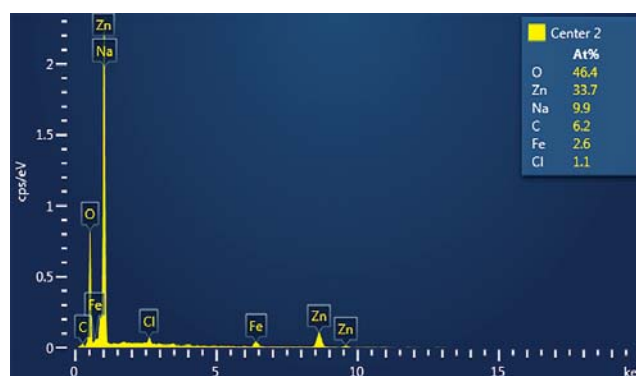

Figure 2. EDS analysis of the porous Zn-coated steel surface

several holes that increased the roughness interface. On the other hand, this was one of the two important factors that made the hydrophobic surface [14 - 19].

The composition of Zn thin coated on steel substrate was analysed by EDS as shown in Figure 2 which displayed the presence of zinc (8.6keV and 1.0keV). From the data, it is

apparent that thin Zn layers have been successfully introduced through the simple deposition method, in agreement with the published data [10].

The wettability of surface was performed by water contact angle (CA) measurement as shown in Figure 3. The steel interface without coating Zn and silane group ($\text{CH}_3\text{-Si}$) was hydrophilic with CA of $54^\circ \pm 2^\circ$, however, this steel surface became hydrophobic after silanisation with CA of $126^\circ \pm 2^\circ$, and superhydrophobic with water CA of $152^\circ \pm 2^\circ$ after coating of micro-nanostructured zinc and silanisation. Indeed, the steel surface was rough and did not contain any material owning low energy surface, resulting in the hydrophilic surface ($\text{CA} < 90^\circ$). After silane modification, CH_3 group which has a low energy surface was terminated on the steel surface, it leads to the hydrophobic steel substrate ($\text{CA} > 90^\circ$) [3, 4]. By micro-nanostructured zinc deposition on the steel surface, the rough surface was increased and the efficiency of silanisation reaction was improved, thus, the hydrophobic properties of the surface was dramatically enhanced, resulting in the superhydrophobic carbon steel surface with modification as shown in Figure 4a. Figure 4b presents the typical sequence of water droplet deposition on the sample, the information shows that it was

difficult to deposit a water droplet on this surface, in other words, the droplet was able to roll off the surface with a small sliding angle ($< 4^\circ$), it means that the surface had a low hysteresis with water.

4. Conclusions

We have successfully achieved the superhydrophobic steel surface via the simple method. By coating $5.5\mu\text{m}$ micro-nanostructured Zn layer and silanisation with methyltrichlorosilane, the carbon steel surface displays superhydrophobicity with water contact angle of $152^\circ \pm 2^\circ$ and low hysteresis. As the superhydrophobic surfaces can repel water, this superhydrophobic carbon steel surface could be ideal for anticorrosion application for the carbon steel pipeline.

References

1. Y.Y.Yan, N.Gao, W.Barthlott. *Mimicking natural superhydrophobic surfaces and grasping the wetting process: A review on recent progress in preparing superhydrophobic surfaces*. *Advances in Colloid and Interface Science*. 2011; 169(2): p. 80 - 105.
2. Nguyen Thi Phuong Nhung, Philippe Brunet, Yannick Coffinier, Rabah Boukherroub. *Quantitative testing of robustness on superomniphobic surfaces by drop impact*. *Langmuir*. 2010; 26(23): p. 18369 - 18373.
3. Nguyen Thi Phuong Nhung, Rabah Boukherroub, Vincent Thomy, Yannick Coffinier. *Micro- and nanostructured silicon-based superomniphobic surfaces*. *Journal of Colloid and Interface Science*. 2014; 416: p. 280 - 288.
4. Nguyen Thi Phuong Nhung, Renaud Dufour, Vincent Thomy, Vincent Senez, Rabah Boukherroub, Yannick Coffinier. *Fabrication of superhydrophobic and highly oleophobic silicon-based surfaces via electroless etching method*. *Applied Surface Science*. 2014; 295: p. 38 - 43.

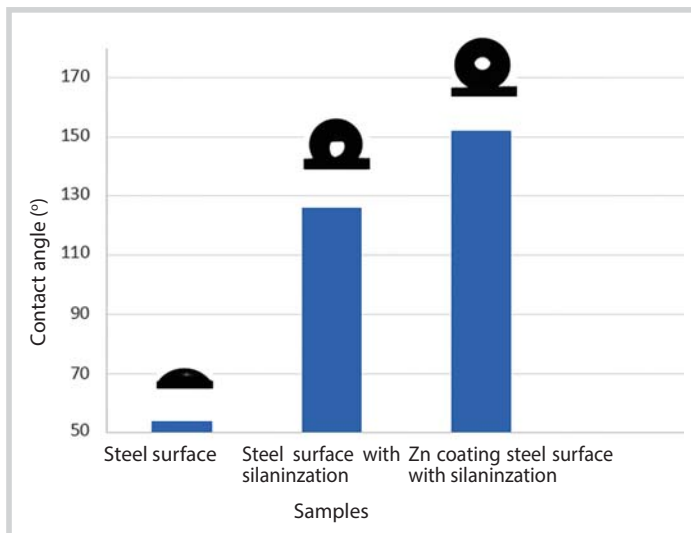

Figure 3. Wetting properties of substrate: steel substrate, steel substrate with silanisation, zinc coated steel substrate with silanisation

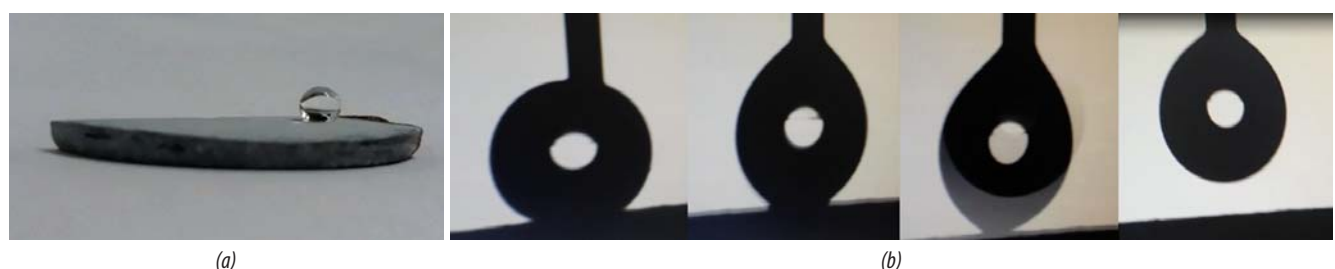

Figure 4. Wetting properties of substrate: steel substrate, steel substrate with silanisation, zinc coated steel substrate with silanisation

5. Philippe Brunet, Florian Lapierre, V.Thomy, Yannick Coffinier, Rabah Boukherroub. *Extreme resistance of superhydrophobic surface to impalement reversible electrowetting related to the impacting/bouncing drop test*. *Langmuir*. 2008; 24(19): p. 11203 - 11208.
6. Nan Wang, Dangsheng Xiong. *Superhydrophobic membranes on metal substrate and their corrosion protection in different corrosive media*. *Applied Surface Science*. 2014; 305: p. 603 - 608.
7. Adel M.A.Mohamed, Aboubakr M.Abdullah, Nathalie A.Younan. *Corrosion behavior of superhydrophobic surfaces: A review*. *Arabian Journal of Chemistry*. 2015 8(6): p. 749 - 765.
8. Haifeng Zhang, Liang Yin, Xiaowei Liu, Rui Weng, Yang Wang, Zhiwen Wu. *Wetting behavior and drag reduction of superhydrophobic layered double hydroxides films on aluminium*. *Applied Surface Science*. 2016; 380: p. 178 - 184.
9. Yi Qi, Zhe Cui, Bin Liang, Richard S.Parnas, Houfang Lu. *A fast method to fabricate superhydrophobic surfaces on zinc substrate with ion assisted chemical etching*. *Applied Surface Science*. 2014; 305: p. 716 - 724.
10. Haiyan Gao, Shixiang Lu, Wenguo Xu, Sabine Szunerits, Rabah Boukherroub. *Controllable fabrication of stable superhydrophobic surfaces on iron substrates*. *RSC Advances*. 2015; 5(51): p. 40657 - 40667.
11. Ge He, Shixiang Lu, Wenguo Xu, Sabine Szunerits, Rabah Boukherroub, Haifeng Zhang. *Controllable growth of durable superhydrophobic coating on a copper substrate via electrodeposition*. *Physical Chemistry Chemical Physics*. 2015; 17(16): p. 10871 - 10880.
12. Lester Li, Victor Breedveld, Dennis W.Hess. *Creation of superhydrophobic stainless steel surface by acid treatment and hydrophobic film deposition*. *American Chemical Society*. 2012; 4(49): p. 4549 - 4556.
13. J.D.Brassard, D.K.Sarkar, J.Perron, A.Audibert-Hayet, D.Melot. *Nano-micro structured superhydrophobic zinc coating on steel for prevention of corrosion and ice adhesion*. *Journal of Colloid Interface Science*. 2015; 447: p. 240 - 247.
14. Hongqin Liu, Sabine Szunerits, Marcin Pisarek, Wenguo Xu, Rabah Boukherroub. *Preparation of superhydrophobic coating on zinc, silicon, and steel by a solution-immersion technique*. *Applied Materials & Interface*. 2009; 1(9): p. 2086 - 2091.
15. Li Wang, Jieyi Yang, Yan Zhu, Zhenhua Li, Tao Sheng, De Quan Yang. *An environment-friendly fabrication of superhydrophobic surfaces on steel and magnesium alloy*. *Materials Letters*. 2016; 171: p. 297 - 299.
16. Liang Yin, Haifeng Zhang, Yuyang Li, Yang Wang, Ruimin Zhang, Weiping Chen, Xiaowei Liu. *Fabrication of biomimetic superhydrophobic steel surface under an oxygen rich environment*. *Applied Surface Science*. 2016; 380: p. 40 - 46.
17. Hongmei Zhang, Jin Yang, Beibei Chen, Mingsuo Zhang, Changsheng Li. *Fabrication of superhydrophobic textured steel surface for anti-corrosion and tribological properties*. *Applied Surface Science*. 2015; 359: p. 905 - 910.
18. Yi Fan, Yi He, Pingya Luo, Xi Chen, Bo Liu. *A facile electrodeposition process to fabricate corrosion-resistant superhydrophobic surface on carbon steel*. *Applied Surface Science*. 2016; 368: p. 435 - 442.
19. Li Wang, Jieyi Yang, Yan Zhu, Zhenhua Li, Tao Sheng, Y.M.Hu, De Quan Yang. *A study of the mechanical and chemical durability of Ultra-Ever Dry Superhydrophobic coating on low carbon steel surface*. *Colloids and Surfaces A: Physicochemical and Engineering Aspects*. 2016; 497: p. 16 - 27.

CARBONYL SULFIDE PRESENCE IN SYNGAS STREAM PRODUCED FROM BIOMASS GASIFICATION PROCESSES: MEASUREMENT AND CALCULATION

Le Dinh Chien¹, Ngo Thanh Hai², S.T.Kolaczkowski³, D.W.J. McClymont³

¹Vietnam Oil and Gas Group

²Hanoi University of Mining and Geology

³University of Bath, United Kingdom

Email: chienld@pvn.vn

Summary

For a biomass gasification process, the removal of sulfur dioxide (SO₂) and hydrogen sulfide (H₂S) from the dirty producer gas is considered to be relatively easy (e.g. by scrubbing); however, the removal of carbonyl sulfide (COS) is more difficult. To help with the development of a suitable gas clean-up strategy, the presence of COS species was considered in more detail in this study by both experimental measurements and theoretical thermodynamic equilibrium calculations. The results indicated that the theoretical thermodynamic equilibrium calculation showed a good match with experimental data, when equilibrium temperature of over 900°C was assumed. It is interesting to note that the temperature of over 900°C was also the highest temperature observed in the hot zone of gasification experiments.

Key words: Biomass gasification, thermodynamic equilibrium, on-line gas analysis, quadrupole mass spectrometer (QMS), sulfur, gas clean-up.

1. Introduction

In a down-draft air biomass gasifier, the fuel to air equivalence ratio is about 0.25 [1]. This means that only 25% of the stoichiometric requirement of air (to achieve complete combustion) is provided. The reactions between hydrogen and sulfur compounds are likely to lead to the formation of H₂S, and the oxidation reactions could lead to the formation of SO₂. However, other reactions can also lead to the formation of lower quantities of COS. The removal of SO₂ and H₂S from the dirty producer gas was considered to be relatively easy (e.g. by scrubbing) while the removal of COS is more difficult.

Depending on the source of biomass (e.g. refuse-derived fuel), its sulfur content will vary. As an example, based on information from one supplier [2], the sulfur levels of refuse-derived fuels can vary from 0.12 to 0.17wt%, yet can even be as low as 0.09wt%, or peak as high as 0.3wt%. These variations have huge implications for the design of the subsequent gas clean-up processes, especially as the final emission limits on the plant must conform to the Waste Incineration Directive (2000/76/EC), otherwise known as WID limits [3].

From an engine maintenance perspective, feeding a heavily contaminated gas into a reciprocating engine is not desirable. Any residual sulfur compounds in the gas:

(a) may act as catalyst poisons and affect the performance of the catalysts used to clean up the emissions in the exhaust gas (after the gas engine), or (b) when burnt in the gas engine, are likely converted to oxides of sulfur, which could exceed the WID limits [3] in the exhaust gas emissions from the plant. Also, because of the dilution effect (as air is added), the volumetric flow rate of the exhaust gas is approximately 3x higher than the producer gas fed into the engine. So purely from a volumetric perspective, the size of gas clean-up equipment could increase and so would the associated operating costs.

Therefore, to help with the development of a suitable gas clean-up strategy, the presence of COS species is considered in more detail in this paper, under the following themes: (a) experimental gasification in a quartz tube reactor and a commercial pilot-scale down-draft gasifier: measurements were taken when wood, straw, refuse derived fuel (RDF) and waste-wood pellets were gasified, and the ratio of H₂S and COS species was quantified; (b) theoretical thermodynamic equilibrium calculations.

It is also noted that all experimental works presented in this paper are a brief review of an earlier study [4]. Based on information of gas composition of that previous work [4], a theoretical study was conducted in this paper to see what would be predicted at different values of gas

temperature, and to discover what temperature matched the data most closely.

2. Material and methods

2.1. Experiment

2.1.1. Laboratory-scale gasifier

Gasification experiments were performed in a small laboratory-scale quartz tube gasifier, in which earlier work [5] showed that it can produce a gas stream similar in composition to a pilot-scale gasifier. An outline schematic of the gas sampling scheme is shown in Figure 1.

The gas flowed from the bottom of the gasifier, then through a cooler, and any condensate was trapped in the first plastic vessel. The gas then passed through a cooling coil, where more of the liquid condensed. The gas was then passed through a glass wool filter and then discharged into the vent from the fume cupboard. Samples of gas were drawn from the exhaust line and passed through another glass wool filter and a filter coalescer before going to a gas chromatograph (GC) and a QMS for analysis. This system of filters helped to remove the majority of tars and particulates in the gas stream, so as not to damage the analytical equipment. Further details on this experimental set-up are available in earlier work [5, 6].

2.1.2. Measurements on a pilot-scale plant

Gas analysis measurements were also taken on a commercial pilot-scale plant operated by Refgas Ltd. at a test site in Sandycroft (near Chester, UK). A 'waste-wood' was used as a fuel. The term "waste-wood" is used to describe a material that has been mainly produced from

recycled wood, but may also contain a small amount of other contaminants (e.g. plastic, paper).

In its present configuration, this pilot-scale plant had a nominal capacity of 150 to 250kg/h, depending on the material fed into the gasifier and the choice of operating conditions. The potential electrical output from the gas produced from this plant could vary from 150 to 250kWe.

A simplified schematic of the process flow diagram is shown in Figure 2.

The waste-wood chips were fed from a hopper into the gasifier. The down-draft gasifier operates under a negative pressure, and the gases are drawn from the gasifier by the centrifugal gas blower. The gas leaves the reactor at the bottom of the unit, at a temperature of about 550°C. Char is discharged from the base of the gasifier, and char fines/ash are also trapped in the two cyclones. The dirty gas from the cyclones is quenched with water and then passes through a HESS unit (which is a high-efficiency water scrubber), and a heat exchanger (chiller). The blower draws the gas from the gasifier, and then blows it through the filters, into the storage tank, and then to the gas engine, and/or to the gas flare.

The gas sample to the QMS was drawn from the line, at the point where the gas was sent to flare (Figure 2). At this point, the gas was at positive pressure. The gas sample then flowed through a glass wool filter and a filter coalescer, the same procedure to protect the QMS as shown in Figure 1, before going to the QMS for analysis.

Further details on this experimental set-up are available in earlier work [4].

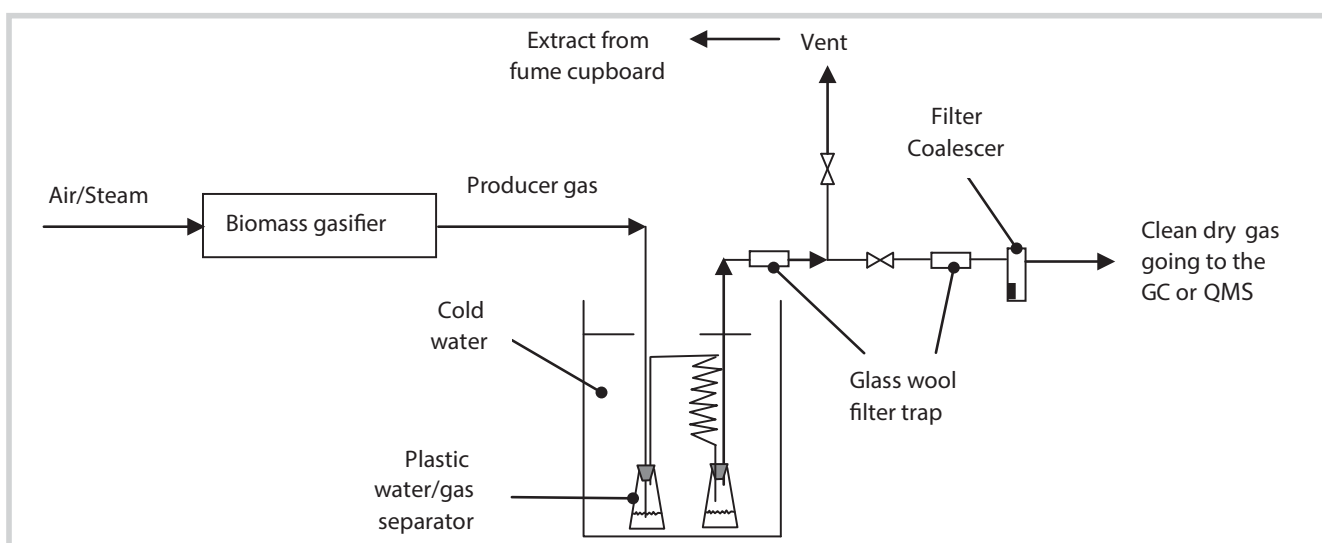

Figure 1. Outline schematic of the gasification experiment, focusing on gas analysis

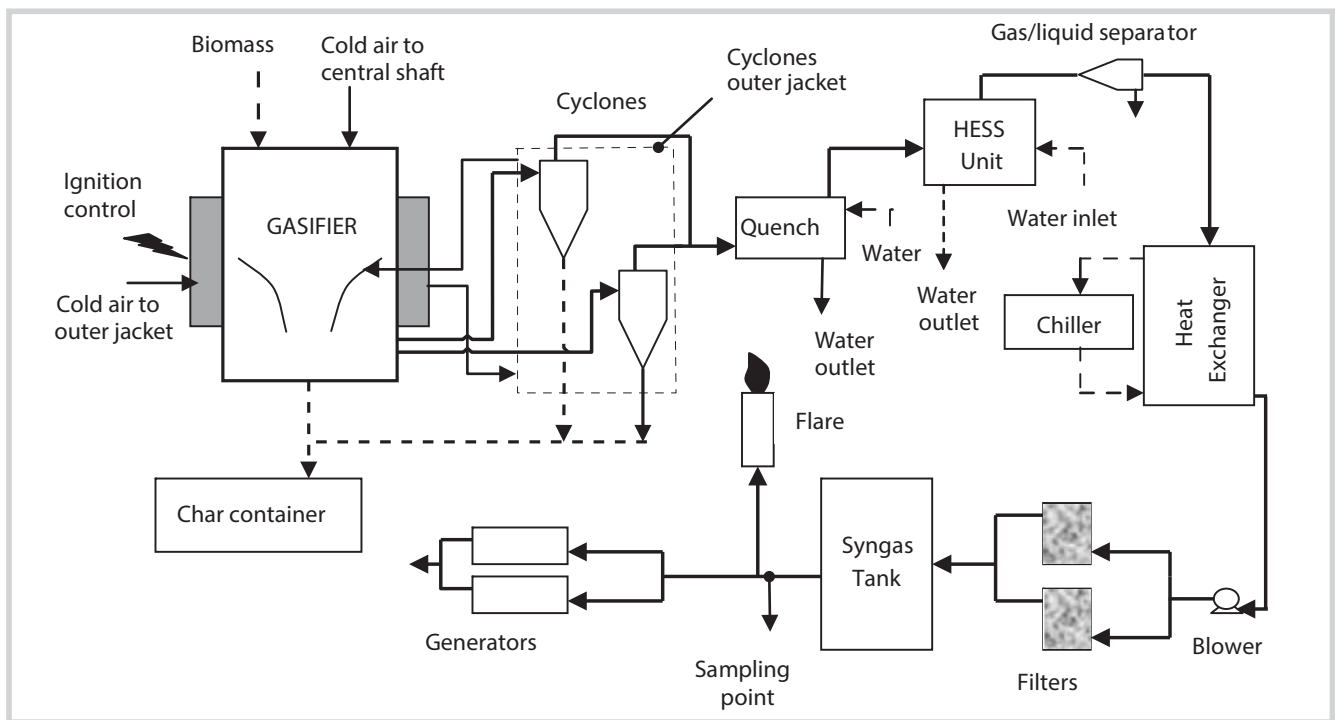

Figure 2. Simplified process flow diagram of the commercial pilot-scale plant

Table 1. Properties of the fuels used with/for proximate analysis

Properties	Waste wood chips ⁽¹⁾	Wood pellets ⁽²⁾	Straw pellets ⁽³⁾	RDF pellets ⁽⁴⁾
Dimensions:				
- Diameter (mm)	-	5	6	14
- Length (mm)	-	5 - 17	5 - 17	30 - 80
Moisture (wt% in wet basic)	10.0	7.4	10.9	7.2
Volatiles (wt% in wet basic)	70.6	72.6	65.9	39.7
Fixed carbon (wt% in wet basic)	19.1	18.8	21.7	29.2
Ash (wt% in wet basic)	0.3	1.3	1.4	23.9

⁽¹⁾ Obtained from an actual pilot-plant, Refgas Ltd, Sandycroft; ⁽²⁾ Supplied by Treenergy Ltd, Monmouth; ⁽³⁾ Supplied by Agripellets Ltd, Evesham; ⁽⁴⁾ Supplied by Refgas Ltd, Sandycroft

2.2. Analysis

2.2.1. Gas analysis

In this study, for experimental measurements, a standard Hiden HPR-20 Quadrupole Mass Spectrometer (QMS) was used to analyse the gas produced from gasification processes. A quantitative method of on-line gas analysis was then developed on this QMS to measure the gas composition of up to 8 species (e.g. N₂, CO, CO₂, H₂, CH₄, O₂ and traces of H₂S and COS) when a range of fuels was gasified.

The repeatability of measurements using the QMS was checked, where a bag-sample of gas was taken during one gasification experiment. The gas was then connected to the QMS sampling line for checking over a 10-minute period. It was found that, during the checking time, the average composition of the species was: N₂ = 58.34 (± 0.28) vol%; CO = 15.62 (± 0.16) vol%; H₂ = 9.1 (± 0.16) vol%, CO₂ = 14.31

(± 0.09) vol%, CH₄ = 1.48 (± 0.01) vol%, O₂ = 9987 (± 80) ppmv, H₂S = 83 (± 5) ppmv, COS = 6.55 (± 0.11) ppmv.

Further details on this method are described in earlier work [4].

2.2.2. Proximate analysis of fuels

The proximate analysis of fuels gasified in this study was done in the laboratory in earlier work [4], and is shown here in Table 1.

2.2.3. Thermodynamic calculation

For theoretical thermodynamic equilibrium calculation, a commercial package, known as Aspen Plus[®] (version 7.1), using Gibbs free energy minimisation, was used. Making use of the software in Aspen Plus[®], calculations were performed where the interaction between many species was considered, and this included: H₂, CO, CH₄, CO₂, N₂, O₂, H₂O, SO₂, SO₃, H₂S, COS, and CS₂.

The work on the theoretical equilibrium calculations was previously published [7].

3. Results and discussion

3.1. Laboratory-scale gasification experiment

3.1.1. Composition of the gas produced

These experiments were performed with/on a small scale, 21mm i.d. quartz tube gasifier filled with wood pellets (5mm diameter and 13mm length), to a depth of about 400mm. The air flow was kept constant at 3 litres/min, and temperatures in the hot zone were in the region of 912 to 1,046°C. Further information on that experimental facility is available in [5].

The same experimental procedures were repeated, using straw and RDF pellets, and a brief review of this previous work [4] is presented here as follows:

The average values of gas composition produced from gasification of different biomass sources are shown in Table 2.

It can be seen from Table 2 that there are significant differences in the gas composition generated by gasification of different biomass sources. The straw pellets produce a slightly higher H₂S gas concentration,

Table 2. Comparison of gas compositions produced from different biomass sources [4]

Component	Wood pellets	Straw pellets	RDF pellets
CO (vol%)	16.44	13.91	10.39
H ₂ (vol%)	10.11	12.83	4.97
CH ₄ (vol%)	2.08	2.11	1.11
CO ₂ (vol%)	15.12	17.17	14.57
N ₂ (vol%)	56.06	53.77	67.90
O ₂ (ppmv)	1,510	1,736	10,063
H ₂ S (ppmv)	99	123	286
COS (ppmv)	10	11	28

and the COS concentration is very similar, compared to the wood pellets. This might come from the fact that, according to Little [8], the sulfur content in straw pellets was typically about 0.1wt%, higher than those of wood pellets made from heather (0.07wt%), gorse (0.08wt%), and rhododendron (0.02wt%).

Also, it is not surprising to see that the concentration of H₂S and COS produced from RDF pellets is about three times higher than values from the wood and straw pellets, as the RDF was expected to have a higher sulfur content. Depending on the source of RDF, its sulfur content will vary. For example, sulfur levels, based on information from one RDF pellets supplier [2], generally vary from 0.12 to 0.17wt%, yet can even be as low as 0.09wt%, or peak as high as 0.3wt%.

In addition, there is a consistency in the molar ratio of the concentration of H₂S to COS (i.e. around 10:1) in the gas streams produced from gasification of wood, straw and RDF pellets, in which 1,084°C was the highest temperature observed in the hot zone. This will be a very useful information for development of gas clean-up strategies for commercial plants.

3.1.2. Thermodynamic equilibrium calculation

At this point, it was decided to calculate the thermodynamic equilibrium (using Aspen Plus) for the gas produced from experiments to see what would be predicted at different values of gas temperature, and to discover what temperature matched the data most closely. The gas produced from RDF gasification was chosen, and the moisture content in the gas stream was assumed to 16.5vol% (the reason for choosing this number can be seen in [7]). A range of reaction temperatures from 600 to 1,200°C was explored. The adjusted wet gas composition and the calculation results are shown in Table 3.

Table 3. Variation of species - simulations on a complex system using Aspen Plus®

Species	Adjusted wet gas composition	Temperature					
		600°C	700°C	900°C	1,000°C	1,100°C	1,200°C
H ₂ (vol%)	4.15	9.655	8.636	6.893	6.257	5.739	4.967
CO (vol%)	8.68	4.809	6.062	7.814	8.450	8.969	9.757
CH ₄ (vol%)	0.93	0.065	0.002	0.000	0.000	0.000	0.000
CO ₂ (vol%)	12.17	16.710	15.493	13.742	13.105	12.586	11.797
N ₂ (vol%)	56.71	56.214	56.143	56.140	56.140	56.140	56.137
O ₂ (vol%)	0.84	0.000	0.000	0.000	0.000	0.000	0.000
H ₂ O (vol%)	16.5	12.521	13.638	15.385	16.022	16.540	17.316
H ₂ S (ppmv)	239	253	251	247	244	239	224
COS (ppmv)	23	7	9	13	15	17	18
SO ₂ (ppmv)	-	0	0	0	1	4	18
SO ₃ (ppmv)	-	0	0	0	0	0	0
CS ₂ (ppmv)	-	0	0	0	0	0	0

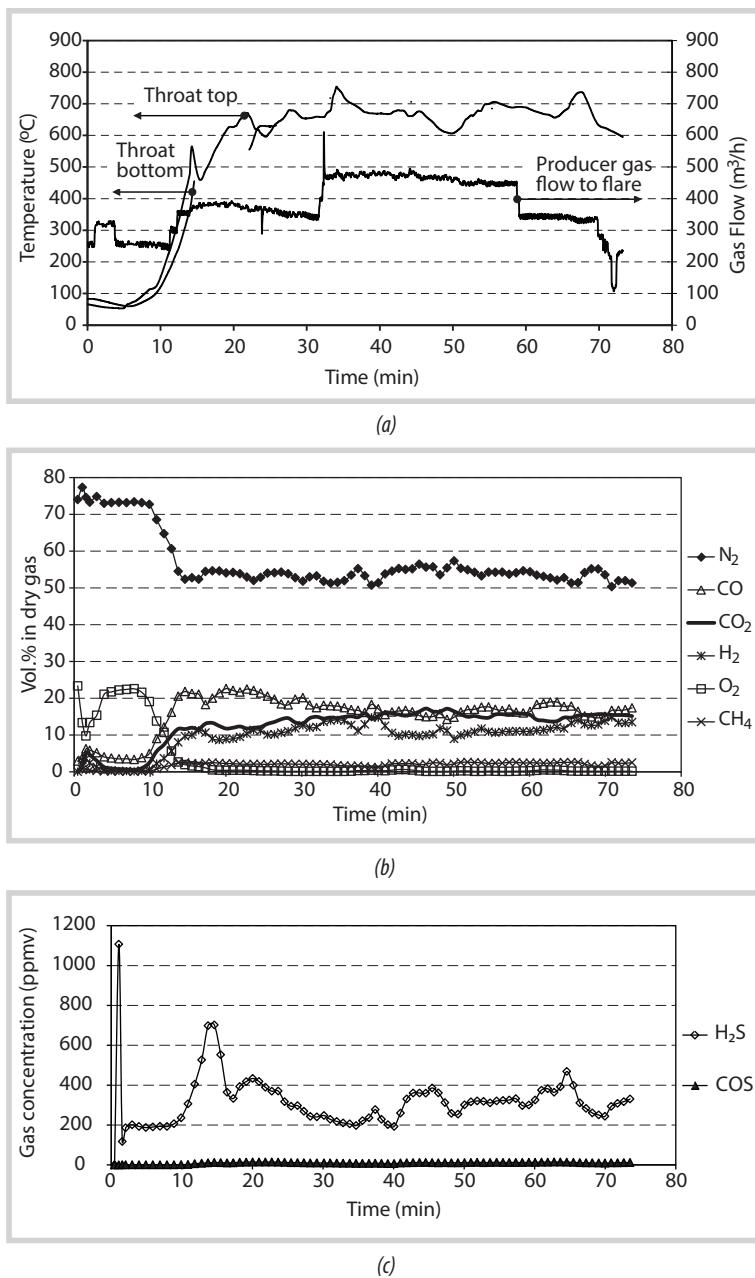

Figure 3. The results of a test run performed on the pilot-plant: temperature and gas flow (a), dry gas composition (b) and concentration of H₂S and COS in dry gas (c) [4]

From Table 3, it is likely that the gas composition estimated matches the experimental data at calculation temperatures higher than 900°C. This may be reasonable because the reaction rate is high at high temperature, and thermodynamic equilibrium could be reached quickly. The temperature of 1,100°C seems to match the data most closely, and it is also nearly the highest temperature observed in the hot zone of gasification experiments [5].

It is interesting to see that the molar ratio of H₂S to COS at calculation temperature of 1,100°C is about 14:1, which is close to the one (10:1) obtained from experiments. Also, the presence of SO₂ becomes significant at high temperature (e.g. 4ppmv at 1,100°C).

For thermodynamic equilibrium calculation, the concentrations of sulfur species also vary with the moisture content of the gas stream. It was found that, for set values of the moisture content between 8 to 20vol%, the temperature of 1,100°C always gave the best match. Therefore, it may be useful to see what moisture content matches the experimental data best at a temperature of 1,100°C. By adjusting the moisture content of the gas stream in the Aspen Plus model, it was found that the value of 10 to 13vol% of moisture gave the best match, where the molar ratio of H₂S to COS was approximately the same as the experimental value (10:1).

3.2. Composition of the gas produced from the pilot-plant

Again, a brief review of the previous work [4] on the measurement of the pilot-scale gasification is presented as follows:

Figure 3 presents the change of gas composition during one run of the pilot-scale gasifier. The changes in H₂S and COS levels are shown in Figure 3c, where the concentration of H₂S varies from about 200 to 700ppmv, while the COS concentrations were in the region of 6 to 17ppmv, which are ~30 times smaller than the concentrations of H₂S. This is not surprising due to the variation of the composition of the waste-wood that is being gasified at a particular moment. Also, the molar ratio of H₂S and COS levels from the pilot-plant is not similar to the findings in the laboratory, where the molar ratio of H₂S: COS was around 10:1 for all three types of biomass (wood, straw and RDF pellets). This difference might arise from the possibility of COS hydrolysis reactions taking place, with the presence of ash particles as a catalyst, in the water quench and absorption units, leading to the conversion of COS into H₂S [9].

Using a similar technique, as described in section 3.1.2, for the gas produced from a pilot-scale gasifier, at a number of snap-shots in time, the thermodynamic equilibrium calculations were performed, using the measure values of gas composition at these points. The results

show that there is a good match in the gas composition at a calculation temperature between 800 to 900°C, which was the operating temperature measured in the throat of the pilot-scale gasifier (Figure 3). Also, the measured concentration of COS in the producer gas stream is just slightly lower (e.g. 2ppmv) than the theoretically calculated values (e.g. 12ppmv).

4. Conclusion

From laboratory experiments, there is a consistency in the molar ratio of the concentration of H₂S to COS (i.e. around 10:1) in the gas streams produced from gasification of wood, straw and RDF pellets. This will be a very useful information for development of gas clean-up strategies for commercial plants.

Concentrations of two key sulfur compounds (H₂S and COS) in the gas produced from a commercial pilot-scale gasifier were measured. Concentrations of H₂S varied from 200 to 1,000ppmv, and this is probably connected to the variation in the composition of the waste-wood fed into the gasifier. In addition, the thermodynamic calculated H₂S and COS levels broadly match the experimental measurements for all calculations.

By adjusting the calculation temperature in the thermodynamic equilibrium model, it was found that 1,100°C was the best value that matches the experimental data most closely at every moisture content (from 8 to 20vol%) of the gas phase. It is interesting to note that the temperature of about 1,100°C was also found to be the highest temperature observed in the hot zone of gasification experiments. It was likely that in the gas phase of the gasifier, thermodynamic equilibrium of reactions could be reached at this temperature, as the reaction rate would be high at high temperature.

Also, by adjusting the moisture content of the gas stream in the thermodynamic equilibrium model, the range of 10 to 13vol% of moisture was found to give the best match, where the molar ratio of H₂S to COS was approximately the same as the experimental value (10:1).

Finally, the importance of considering gas clean-up strategy, and how this may in turn affect the ability of the plant to meet the WID limits for SO₂ was explored, and how concentrations in the RDF translate into emissions. Also, the importance of considering the impact of contaminants on catalyst systems was emphasised, rather than just looking at WID limits on their own.

Acknowledgement

We are grateful for the support received from Refgas Ltd. - the company developing biomass to energy processes, and also for the support from the Vietnam Ministry of Education and Training, in the form of a research grant for Dr. Le Dinh Chien.

References

1. H.A.M.Knoef. *Handbook biomass gasification*. BTG Biomass Technology Group. 2005.
2. S.T.Kolaczowski. *Private communication with Shanks Waste Management Ltd*. 2009.
3. *Directive 7000/76/EC of the European Parliament and of the Council of 4 December 2000 on the incineration of waste*. Official Journal of the European Communities.
4. Le Dinh Chien, S.T.Kolaczowski, D.W.J.McClymont. *Using a quadrupole mass spectrometer for on-line gas analysis - gasification of biomass and refuse derived fuel*. Fuel. 2015; 139: p. 337 - 345.
5. S.T.Kolaczowski, Le Dinh Chien, P.Jodlowski. *Gasification of wood pellets in an experimental quartz tube gasifier: How visual 1D experiments can aid 3D design considerations*. Proceedings of the Bioten Conference on Biomass, Bioenergy and Biofuels 2010. CPL Press UK. 2011: p. 720 - 732.
6. Le Dinh Chien, S.T.Kolaczowski. *Steam gasification of a refuse derived char: Reactivity and kinetics*. Chemical Engineering Research and Design. 2015; 102: p. 389 - 398.
7. S.T.Kolaczowski, Le Dinh Chien, S.Awdry. *Equilibrium reactions(s) involving H₂S and COS species - consideration of thermodynamics and implications on the biomass gasification process*. Proceedings of the Bioten Conference on Biomass, Bioenergy and Biofuels 2010. CPL Press UK. 2011: p. 733 - 744.
8. James Little. *Assessment of the use of landscape management arisings as a feedstock for commercial pellet production*. Feasibility Report, Harvest Wood Fuels. 2010.
9. John E.McDaniel. *Method and apparatus for removing carbonyl sulfide from a gas stream via wet scrubbing*. US Patent, No. US 6322763 B1. 2001.

CLIMATE CHANGE REALITY AND IMPLICATIONS FOR THE OIL AND GAS INDUSTRY

Le Ngoc Anh¹, Phan Thi Ngoc Trang²

¹Vietnam Oil and Gas Group

²University of East Anglia

Email: anhln@pvn.vn

Summary

Climate change is now occurring with various influences on the Earth's system, starting from changes in rain patterns, water systems to sea level and many other extreme weather events. The evidences are clear and the governments of many countries have shown solid commitments in the Paris Agreement adopted at the 21st Conference of Parties (COP21) in 2015. Such natural and regulatory changes mean a lot to the oil and gas industry and require immediate actions. This article shows that moving towards natural gas is the right direction that is already happening; but in a longer term, revaluation of assets and investments in renewable energy will even be more beneficial to oil and gas companies in a low-carbon future.

Key words: Climate change, greenhouse gases, oil and gas companies, renewables, risk management.

1. Introduction

The oil and gas industry is experiencing difficult times since the price of crude oil, a benchmark for financial results, has been falling sharply since mid-2014: The lowest value was recorded in early 2016 at USD 28/barrel before the price stabilised at around USD 50/barrel in mid-2016, less than half of the price two years ago [1]. Global economic growth, especially in China and Asia, has not yet been proven to be sustained and still contains downside risks [2]. Most importantly for the long-term operation and development of oil and gas companies: climate change has become a real challenge.

2015 was the hottest year on record, but 2016 is on track to become even hotter by a significant margin. In particular, June 2016 was the hottest June ever for the globe (land and sea), and it is the 14th month in a row that broke the world temperature record, with data dated back to 1880 [3, 4] (The U.S. National Aeronautics and Space Administration - NASA, the U.S. National Oceanic and Atmospheric Administration - NOAA, and the Japan Meteorological Agency - JMA conducted separate measurements, but their figures show similar and consistent trends). Other indirect observations are also alarming: for example, ice in Greenland melted so early and so fast this year that scientists initially thought their data was wrong [5]. Even considering the impacts of El Niño which ends this year, it is obvious that the world is warming and changing. So this article will start with scientific evidences and causes of climate change, before discussing its global impacts and actions by governments and the international community.

After that, specific impacts on the energy sector will be analysed, before concluding with implications for traditional oil and gas companies.

2. Climate change facts and figures

2.1. A short history of climate change

The science of climate and the earth system had a very long history but had not drawn much attention until the term "Climate change" first appeared in a scientific paper by an American scientist in 1975 [6]. During the 1970s, thanks to the development of climate science and technology, especially efforts from governments and the international community, climate change has become an important issue and a part of the agenda for economic-social-environmental discussion. The establishment of the Intergovernmental Panel on Climate Change (IPCC) in 1988, together with the United Nations Framework Convention on Climate Change (UNFCCC) in 1992, the Kyoto Protocol in 1997 and particularly the Paris Agreement at the 21st Conference of Parties (COP21) in 2015 lead to increasing awareness and actions among countries and international companies.

2.2. Evidence and drivers of climate change

To have a big picture about climate change and the role of oil and gas companies, it is necessary to make sure that: (i) the climate is really changing, not just in 2015 or 2016 but in longer periods; (ii) the reasons are mostly human-related; and (iii) oil and gas companies are in the centre of the story.

A global surface temperature dataset produced by the MET Office Hadley Centre in collaboration with the University of East Anglia's Climatic Research Unit (CRU) shows that global average land and sea surface temperatures have increased by about 0.9°C since 1850. Despite the differences in the methodologies used, many of the features of this time series are very similar to surface temperature datasets recorded by the National Aeronautics and Space Administration's Goddard Institute for Space Studies (NASA GISS) and the National Oceanic and Atmospheric Administration - National Climatic Data Centre (NOAA) (Figure 1). Indirect estimates of temperature change from sources such as tree rings and ice cores also indicate that 1983 - 2012 was probably the warmest 30-year period in more than 800 years [7].

Although climate system, temperature in particular, is always changing naturally from year to year and from decade to decade in the early part of the 20th century (Figure 1), these anomaly variations are mostly due to natural causes. For examples, the noticeable warm spikes in the temperature series, such as those in the late 1870s and in 1998, show the influence of El Niño events on global temperature trends; and La Niña events in 1999 - 2000 and 2008 are marked by two brief dips in global temperature. These events are expected to recur every three to eight years. On the other hand, temporary cooling of the Earth's surface is associated with large tropical volcanic eruptions, with the largest effects come from Mt. Agung in 1963 and Mt. Pinatubo in 1991 [8]. However, these short-term variations do not contradict the long-term warming trend as scientists, by studying many different types of climate variations, have concluded that most of the observed increase in global average temperatures since the mid-20th century is very likely due to the observed increase in anthropogenic greenhouse gas concentrations [9].

Besides the temperature records, the dramatic decrease in the extent of Arctic sea

ice is another observational evidence that climate is changing. Ice extent in the North Pole in March 2016 has reached a record low in 13 years for wintertime maximum level [10]. Decreases in Arctic sea ice extent are demonstrated to be much greater than increases in the Antarctic (South Pole). Together with increasing ocean temperature, this has led to the increasing rate of sea level rises, especially in the past decade [11].

Global warming can be simply explained by the "Greenhouse Effect". This process can happen naturally by the effect of atmospheric gases such as water vapour, carbon dioxide, methane and nitrous oxide (e.g. greenhouse gases) absorbing energy from the sun and trapping it within the atmosphere, making the Earth's temperature hospitable for life. However, human activities, primarily fossil fuel burnings and

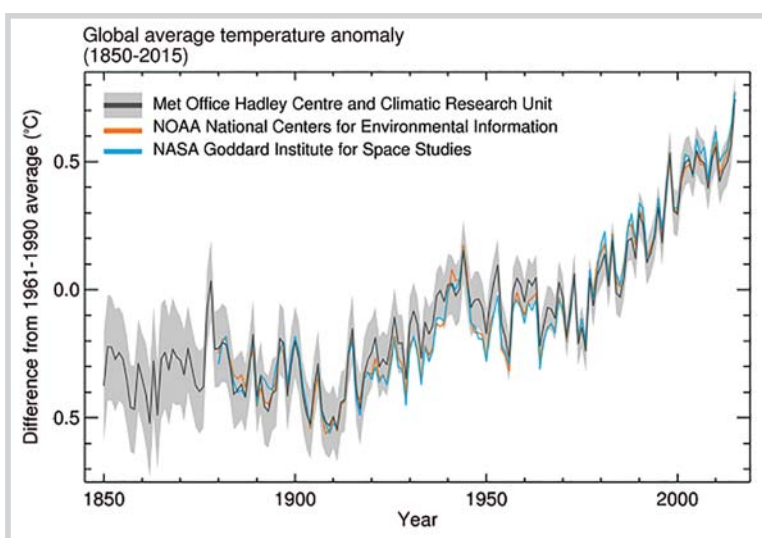

Source: Met Office UK (Last updated: 13rd May 2016)

Figure 1. Global average temperature anomaly (1850 - 2015)

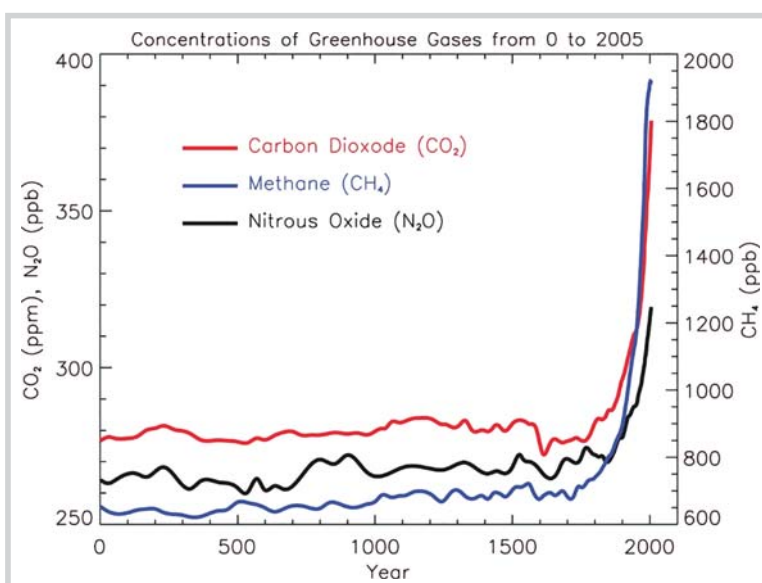

Source: IPCC, 2007

Figure 2. Atmospheric concentrations of important long-lived greenhouse gases

land use changes, have greatly intensified the natural greenhouse effect and are considered the main driver of observed climate change and increasing average Earth's temperature since the mid-20th century [12].

Since 1750, increases have been attributed to the emissions of four principle greenhouse gases: carbon dioxide (CO₂), methane (CH₄), nitrous oxide (N₂O) and the halocarbons (a group of gases containing fluorine, chlorine and bromine) caused by human activities in the industrial era (Figure 2); with the largest known contribution coming from the burning of fossil fuels [12]. Although water vapour (H₂O) is the most abundant and important greenhouse gas in the atmosphere, human activities have only a small direct influence on the amount of atmospheric water vapour. Being the second-most important greenhouse gas, CO₂ becomes the standard measure of climate change for the public.

Prior to the pre-industrial time, the atmospheric mixing ratio of CO₂ remained relatively steady between 260 and 285ppm. Because of anthropogenic emissions, atmospheric CO₂ has climbed to levels that are presently 36% higher (approximately 100ppm) than before the industrial revolution [13]. Since 1750, the concentration of CO₂ in the atmosphere has gradually risen, to nearly 390ppm in 2005 (Figure 2). During this period, the absolute growth rate of CO₂ in the atmosphere also increased substantially. Disruption of the carbon cycle by human activities primarily comes from burning of fossil fuels and deforestation, and also cement production and other changes in land use and management such as biomass burning, crop production and conversion of grasslands to croplands [12]. Figure 3 shows that the global acceleration of CO₂ emissions mainly reflects the world's fossil energy consumption. Over the last 50 years, total consumption of oil, gas and coal has approximately tripled, from 4,623 million tons of oil equivalent (Mtoe) in 1970 to 11,306Mtoe in 2015, equivalent to an increase of roughly 20,000Mt in atmospheric CO₂ concentration. Fossil fuel combustion is responsible for almost 75% of anthropogenic CO₂ emissions [12].

Despite being in relatively smaller abundances compared to CO₂, CH₄ and N₂O are demonstrated to be initially far more devastating to the climate because of their greater ability to absorb radiation [14]. In fact, over a 100-year period, the comparative impact of CH₄ on climate change is more than 25 times greater than CO₂ and that of N₂O is approximately 300 times greater compared to CO₂ [15]. Methane is the primary component of natural gas and also an important greenhouse gas that is currently contributing to about 15% of global anthropogenic greenhouse gas emission every year [12]. Methane is emitted to the atmosphere from a variety of natural and anthropogenic sources [16]. Among the anthropogenic sources, the oil and gas industry is considered one of the main contributors, accounting for 63Tg CH₄ per year [17]. The link between the operation and transportation in the gas industry and CH₄ emissions will be discussed in more details later in this article.

3. Climate change - impacts and actions

Climate change has been affecting many countries and regions in the past decades. Weather extremes, such as heat waves, droughts, and floods, etc, have become more frequent and unpredictable; changes in the rain pattern and the melting of ice/snow have already affected water resources; consequently, water and marine species have migrated differently, while crops in many places have been adversely affected [18]. While it is not obvious to identify and separate the current impacts of climate change alone, it is even more difficult to forecast the impacts in the future - which will be uncertain due to both the complexity of climate science and possible responses of governments, companies, and the people. Therefore, an approach to

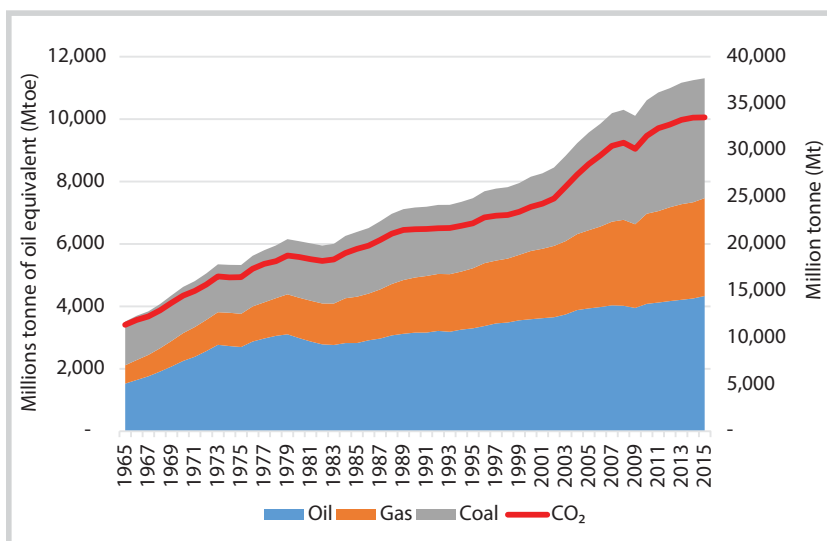

Source: BP
Figure 3. World fossil fuel consumption and CO₂ emissions (1965 - 2015)

identify the general impacts of climate change (Figure 4) will include interaction with the society & economy - whether the actions of the governments, companies, and people can improve or degrade climate conditions. Then, climate change (by both natural and human-related factors) will impact on three major categories: (i) natural or managed resources and systems from water to low-lying lands, species and food supply; (ii) human living in urban or rural areas and a variety of economic sectors; and (iii) human's health, security and poverty.

Based on this approach, it can be seen that the impacts on the oil and gas/energy sector will come from both climate change per se, and from the policy and actions of governments, companies and people. Furthermore, due to the role of energy in almost every aspect of the economy and society, there will be indirect influence from other sectors/issues on energy usage that should be taken into account. While different scenarios for the energy sector will be discussed in Section 4 below, an overall approach to analyse climate change impacts on the energy sector is shown in Figure 5. Climate change and our actions might affect: (i) energy demand, notably

heating and cooling requirements, as well as water, besides other indirect impacts from income, urban and rural living changes; and (ii) energy supply - not only the issue with CO₂ reduction, but also consequences from higher operating temperature, as well as from weather extremes like storms, floods, and hurricanes.

So what have international organisations and governments done about climate change? Their actions will be the key in setting the rules and ground for various stakeholders to behave in the coming decades, especially for energy companies. International efforts to tackle environmental issues started in 1979 at the first World Climate Conference, but only after the setup of the IPCC in 1988, the UNFCCC in 1992, the first Conference of the Parties (COP1) in Berlin in 1995, and especially the Kyoto Protocol in 1997, that concrete results were achieved. The Kyoto Protocol was a binding agreement for 37 industrial countries and the European Community, committing to reduce greenhouse gas emissions through the market mechanism. One outcome was international emissions trading, including the "cap and trade" scheme in the EU (however with limited success on pricing carbon [19]). The

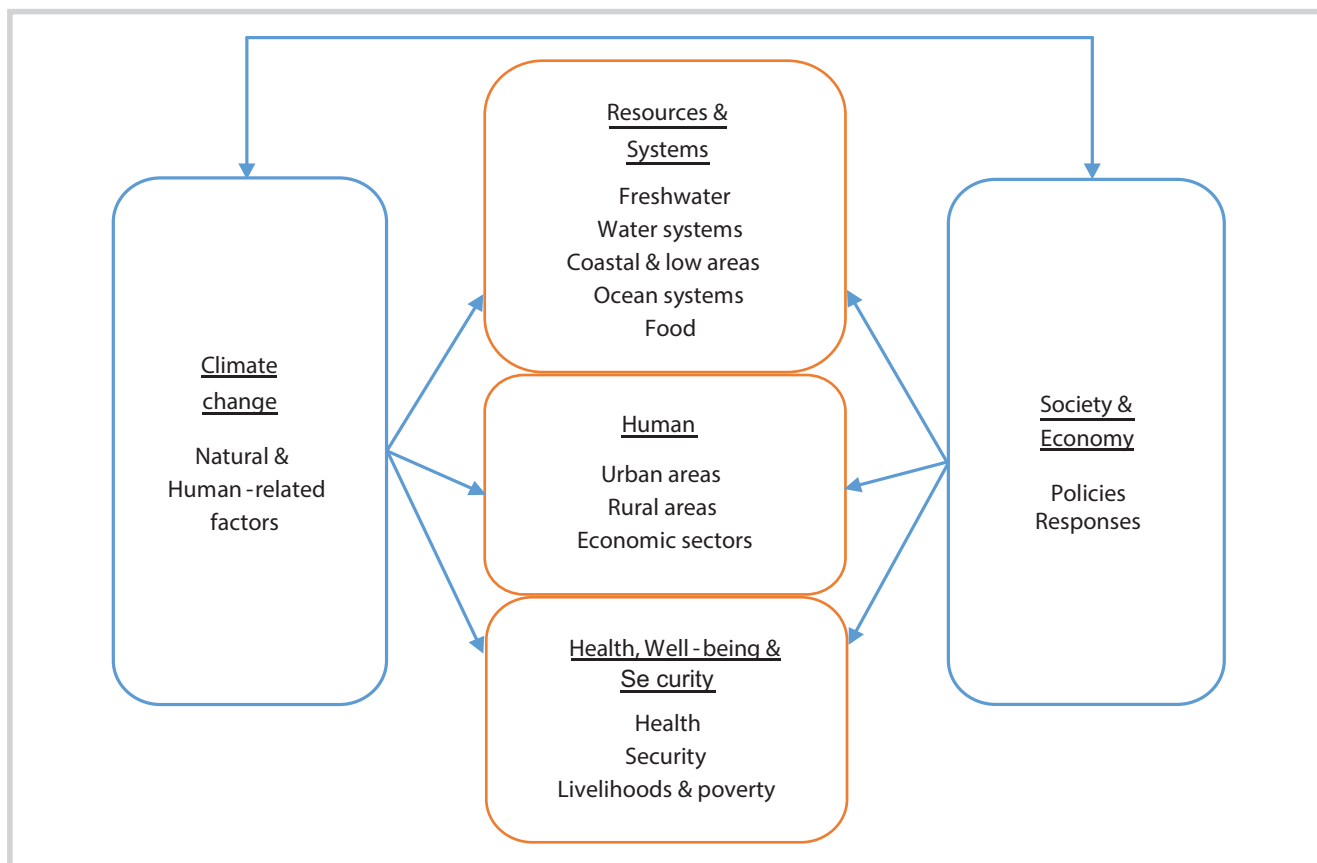

Source: IPCC and compiled by authors

Figure 4. General impacts of climate change on the world

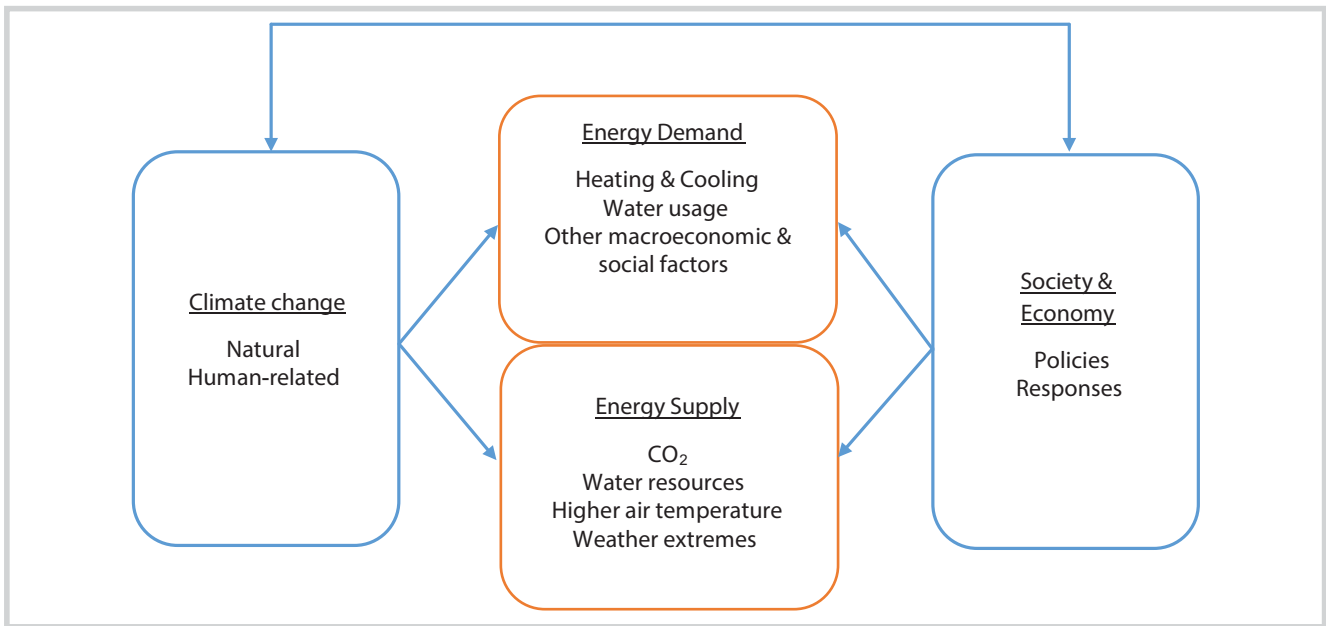

Source: IPCC and compiled by authors
Figure 5. General impacts of climate change on the energy sector

Doha Amendment at COP18 extends the Kyoto commitments from 2012 to 2020, setting the ground for the story of the Paris Agreement at COP21 in 2015.

But the Paris Agreement in 2015 is different and truly a milestone in tackling climate change that all parties, including energy companies, need to pay attention. Legally binding for all 196 parties, the Agreement will start in 2020 and aim to control the temperature increase well below 2°C (with 1.5°C the target) compared with pre-industrial (1850 - 1900) level. This might be a challenging target as seen in Figure 6. Current pledges of countries at Paris COP21, though much better than current policies, are not enough to sufficiently cut CO₂ to limit temperature increase by 2°C, not to mention 1.5°C. But the Agreement is designed to be flexible to make improvements overtime while ensuring the participation of all parties. Specifically, countries will make their own nationally determined contributions (NDC or pledges) for each period and are open to achieve such national targets. But this “soft” and

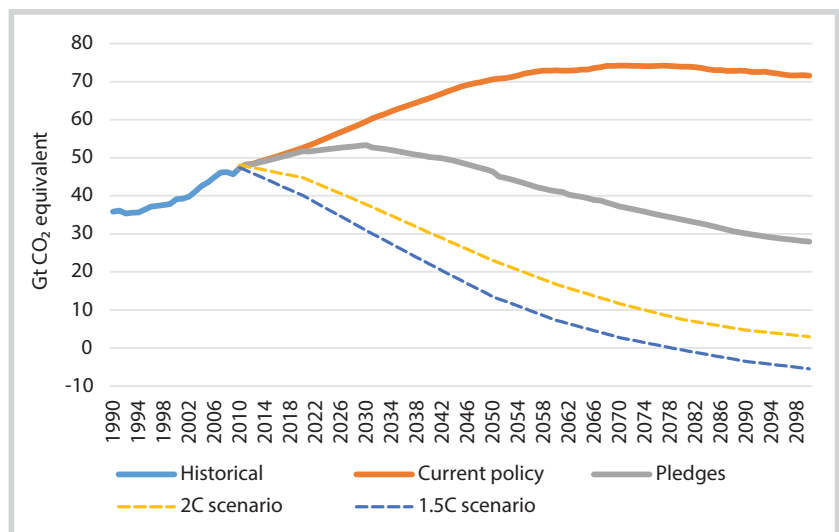

Source: Climate action tracker
Figure 6. CO₂ emission scenarios (2010 - 2100)

“national” enforcement mechanism includes other incentives (even some form of trade sanction) to hopefully make it work better than the “strict” but “international” form in the Kyoto Protocol. Besides, Paris Agreement 2015, for the first time, signals common perspectives of the two largest emitters - the United States and China. This is adequately significant to create more confidence in policy changes across the world [20].

4. Impacts and implications for oil and gas/energy companies

As mentioned above, the interaction between climate change itself and various policy pathways in the future will make it difficult to quantify the impacts of climate change in the oil and gas industry as well as the whole energy sector. Besides, the current research focuses more on energy

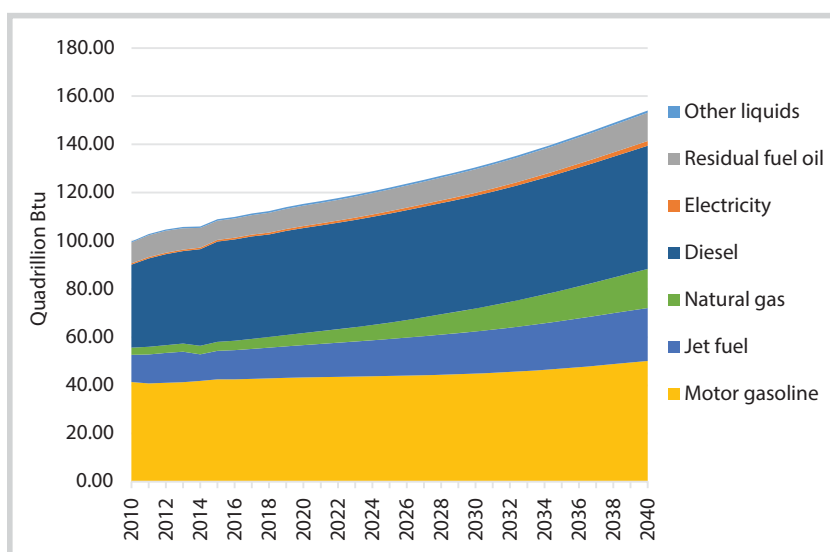

Source: EIA

Figure 7. World transport sector delivered energy consumption (2012 - 2040)

demand, while energy supply and especially energy price also need further studies [18]. Therefore, this section will look at various impacts and scenarios for the energy sector up to 2040, rather than focusing on projected figures up to 2100 as for the climate science. The approach presented in Section 3 will be used, while other key themes for the energy sector in the coming decades will be discussed in the context of climate change.

4.1. Energy demand

4.1.1. Heating and cooling

The most obvious impact of climate change is that temperature is generally increasing, leading to more energy demand for cooling and less for heating. The specific outcome will depend on some other factors such as geographic location, heating/cooling appliances, and income. The biggest increase in demand for cooling will happen in low-income countries in warm weather, especially when better income over time leads to more air conditioner usage. Demand for cooling in summer in high-income countries also goes up, resulting in total electricity demand of 4,000TWh in 2050 for residential air conditioning (up from 300TWh in 2000), 25% of which is due to climate change [21]. On the other hand, heating requirements are overall smaller in winter. This makes the net change in demand for the world might be relatively modest. But the net change can be much higher in regions like South Asia - where cooling demand in summer will be much bigger than heating demand in winter due to increasing temperature, which will be challenging for the power sector to meet the peak load at specific times of the day.

4.1.2. Water usage

Climate change will have a huge impact on water system and water resources. The normal cycle of evaporation and precipitation (rain) will be distorted, as warmer weather leads to higher rate of evaporation, and higher capacity of the atmosphere to "hold" water. As a result, many places will be

drier, while other places will face heavier precipitation (though the total rain fall can be smaller). Besides, hotter weather means people and animals need more water to stay healthy, and food crops need more water to be grown. Not to mention competition for water from other sectors (like energy supply), it will be very challenging to provide enough clean water to the world's population, which is constantly exploding. More energy will be needed to find, purify and bring water to the right users in the right places in the near future. For example, the recent drought in Asia has led to a sharp rise in diesel consumption for agricultural irrigation, and the revival of premium for diesel price in 2016 [22]. However, further study in the area of energy and water under climate change will need to be conducted.

4.1.3. Transportation

Since petroleum and other liquid fuels are the dominant sources of transportation energy, the transport sector has always been the second largest contributor to greenhouse gases emissions since 1970. According to International Energy Outlook 2016, energy consumption in the transport sector is expected to increase at an annual average of 1.4% during the projection period of 2012 - 2040, with motor gasoline and diesel being the largest transportation fuel (Figure 7). With efforts to reduce greenhouse gas emissions, the use of natural gas will increase by 11% but still not yet replace the dominance of petroleum and other liquid fuels.

From a few hundred in 2005, the number of electric cars rose to over 700,000 and hit 1.26 million in 2016 - after increasing by 70% in 2014 - 2015 [23]. The biggest markets are now China, the United States, the Netherlands, and Norway; and top producers including

Tesla, Chevy, and Nissan. The Paris Declaration on Electro-Mobility and Climate Change and Call to Action (announced at COP21) aims for 100 million electric cars by 2030; while to achieve the 2°C scenario, IEA estimates about 140 million cars by 2030 will be needed [23]. Such ambitious plan will require various factors: such as governments' support (price, infrastructure), consumers' acceptance (price, fuelling/charging habit), and crucially - lower battery costs. The last factor has been happening in the past few years, with cost decreasing from USD 1,000/kWh in 2008 to USD 268/kWh in 2015, or 73% in 7 years. It is estimated that battery cost can fall to about USD 125/kWh by 2030, a level that makes electric car cost-competitive with conventional engine types [23].

So what will be the impact for oil demand? There have been various projected figures. BNEF [24] claims that 45% annual growth of electric car sales (compared with 70% growth in 2015) will displace about 2 million barrels of oil per day in 2028 - more than the supply surplus that pushed oil price to record low in 2015. Another report [25] forecasts that if climate change commitment can be successfully implemented (CO₂ concentration less than 450ppm), it will make oil demand in 2028 lower than today. Even with moderate success, climate change policy will make oil demand flat around 2028, and be lower in 2040 - compared to today. These figures can even be lower if the trend in car sharing - or mobility as a service (not necessarily owning a car), continues in the future [26]. This all means a lot of work for oil and gas companies in the coming one or two decades.

4.2. Energy supply

4.2.1. CO₂ emission limit

An ambitious plan to cut CO₂ emissions means the energy supply mix, especially for power generation, will change significantly. High-carbon fuel like coal and oil will face difficulties in terms of environmental regulations and price competitiveness - given possibly higher price for carbon and the rise of alternative and renewable energy. Coal-fired power plants growth will come to an end, except for India; and the fuel to replace coal and dominate power generation in the first half of this century will be natural gas with its share hitting 24% in 2030 under the IEA's Bridge Scenario (a medium case between the current pledges by countries and the CO₂-450-ppm scenario to meet 2°C). Notably, renewables (excluding hydro) expand quickly and contribute 19% to power generation in 2030, with wind being the largest (9%) and solar the fastest-

growing (4% of power generation mix) [27]. Projections from Wood Mackenzie [28] also show a similar trend for renewables, with share in the power sector over 20% by 2035. The drive for solar expansion again has been fast falling cost. Up-front project cost for solar in the United States has dropped from 6.3cents/W in 2009 to 3.1cents/W in 2014 (with some as low as 2cents/W). This results in power sale agreements at just 5cents/W in 2014 [29]. So solar costs have cut more than half since 2009, and together with more efficient operation (utility-scale capacity factor up from about 25% in 2012 to 29.4% in 2014), solar is expected to expand quickly in China, India, and Australia besides the United States and Europe. Wood Mackenzie even considers solar the new shale for the energy sector [30].

4.2.2. Water resources

The impact of climate change on water resources and power generation is quite complex. For thermal power plants, the possibility of reduced water sources and somewhat warmer water used for cooling will result in less electricity output, with load reduction from 0.1 to 5.6%. The impact for hydropower is even more complicated, with more or less water for different regions, changing the rain patterns during the year, and different flood control by the authorities because of climate change. In general, it is expected that climate change will bring positive effects (higher generation) to hydropower in Asia, while negative effects to that in Europe [18]. Again, the interaction between water and energy is a big issue especially under the climate change context and requires further studies.

4.2.3. Higher temperatures and weather extremes

Another impact of climate change on the supply and transmission of electricity is reduced operating efficiency due to higher air temperature. This will mostly impact current power plants with older technology, and the economic costs might not be very significant. On the other hand, weather extremes like hurricanes, storms, high wind, heavy rains, and floods can cause severe damages to the production and transportation of energy. One example is the destruction of the Fukushima Daiichi nuclear power plant after an earthquake and the subsequent tsunami in March 2011, resulting in massive radioactive contamination of the Japanese mainland. Such low probability but severe-consequence event will need more research in both climate/earth science and technical solutions. Weather extremes can also have

impacts on the safety and operation of the pipelines and electricity grid, requiring better design and construction standards in the future.

4.3. Implications for energy companies

The many sides of climate change and its impacts mean there are winners and losers in the energy business in the future. Obviously, traditional oil and gas companies - who owns upstream and downstream petroleum assets - will face the biggest challenges. Renewables companies - who invest in wind, solar and biomass - seem to be on the right side of the road, though their business models are yet to mature. Utilities companies - who buy and sell electricity - will face different risks, and have to choose the appropriate generation mix, given technical, economic and regulatory constraints. There are winners and losers due to their geographic locations as well, as for hydropower plants. So this section will look at the most talked about stakeholders - a traditional oil and gas company, with some exposure mentioned above.

4.3.1. Less oil, more gas

The pressure for oil is obvious, not only due to its high-carbon content but also the changing nature of transportation. Oil and gas companies now actually emphasise more on the second part of their name - natural gas. The mega deal recently is Shell's acquisition of BG to own natural gas assets in Australia and become the biggest LNG trader [31]. This is what McKinsey called Big Oil becoming Big Gas [32]. Other companies also take actions to show their favour for the cleanest fossil fuel. Specifically, in time with the Paris COP21, ten of the world big oil companies formed a group called the Oil and Gas Climate Initiative^(*) to confirm their support for climate change targets (though no specific plan or commitments were made). One of their key actions is moving towards gas, with emphasis on safe and sound operation to limit methane (CH₄) emissions. This is also in line with the latest effort by the United States to have for the first time a regulation on methane [33] - requiring companies to stop methane leaks from new and modified drilling wells and storage tanks. Although efforts to reduce greenhouse gas emissions require significant investment, reduction projects that target methane present a unique opportunity by capturing and using it as a source of energy. It is indicated that by only focusing on reducing methane emissions from oil and natural

gas operations, the industry can benefit from increased revenues, enhanced operational efficiency and improved environmental performances [34]. All these developments show that natural gas will be the dominant product of traditional oil and gas companies.

4.3.2. Managing the money

The slide of oil price since mid-2014 might be a good practice for oil and gas companies to transit to a low-carbon economy. Price forecast is always difficult and uncertain, but the old hypothesis that oil price will generally go up because reserves are exhausted and the remaining ones are more difficult and costly to find/produce seems to be out of date now [35]. The shale story from the United States has shaken the oil industry and the used-to-be-powerful OPEC. But climate change commitments and renewable technology are really the long-term trend that affect oil consumption, change oil producers' behaviours, and make oil not the fuel that the world must exhaust to run itself. Besides the cyclical ups and downs of the industry, oil price will be relatively lower for longer. Managing the money received and continuing cost optimisation will be the key for upstream companies. This is not to mention the difficulty in funding fossil fuel investment, triggered by campaign for divestment from coal or oil and gas companies. The campaign includes well-known figures in the industry like the Norway's sovereign wealth fund and the Rockefeller Family Fund [36]. Long-term outcomes to be seen, but oil and gas company must be prepared to reassess their financing options under climate change.

In relation with investment and financing, there is a more popular theme that involves lots of debate at the moment: stranded assets or unburnable carbon. The governor of the Bank of England [37] made headlines in 2015 when publicly warned about the risk that fossil fuel companies' assets could be left "stranded" because of climate change. This means huge corrections in oil and gas companies' valuation, shifts in investment, changes in credit ratings, and possibly other financial market instability due to the size of such companies. This is a big topic and requires further studies, but at least oil and gas companies have to reassess their reserves and other assets in the light of climate change, within the right time horizon. Possibly then, National Oil Companies (rather than International Oil Companies) with reserve/production ratio over 30 years will need to be more prepared [38].

^(*) Current members include BP, CNPC, Eni, Pemex, Reliance Industries, Repsol, Saudi Aramco, Shell, Statoil, Total - none of which are US companies (www.oilandgasclimateinitiative.com)

4.3.3. Into renewables

Perhaps the best answer to climate change is switching to renewables. Some oil and gas companies have already done this: Shell recently put USD 1.7 billion into its New Energies division to cover many areas from wind power, biofuel to hydrogen [39]; while Total pushed even further, buying battery manufacturer Saft for USD 1.1 billion, after already investing USD 1.4 billion in SunPower - one of the largest solar companies in the United States [40]. Such strategies will give traditional oil and gas companies the exposure with the fast-changing renewable energy industry but it should be noted that the distributed/ decentralised nature of renewables will be very different to the centralised feature of the oil and gas industry [38].

5. Conclusions

Climate change has become a risk, rather than something uncertain, for the world. Its impacts are wide-ranging and dependent on the responses of governments, companies, and people. For the energy sector, climate change will bring direct impacts for demand and supply, in key areas such as air temperature, water usage, and weather extremes. But more importantly, climate change has led to new regulations, changes in economics and finance of the oil and gas industry, that related companies must be prepared and take actions. The move to natural gas is happening and looks like the right direction in the medium term. But more efficient management of cash flow from traditional oil and gas business, timely revaluation of such assets, and move into renewable energy will be the solutions for the long-term.

References

1. David Sheppard, Neil Hume. *Five things to watch for as oil nears \$50 a barrel*. Financial Times. 2016.
2. Enda Curran, Toru Fujioka, Andrew Mayeda. *G-7 warns on weak global growth as Japan bristles over Yen*. Bloomberg. 2016.
3. Tom Randall. *Summer-on-steroids kicks off with record global temperatures*. Bloomberg. 2016.
4. Patrick Lynch. *2016 climate trends continue to break records*. National Aeronautics and Space Administration (NASA). 2016.
5. E.Holthaus. *Greenland's ice sheet is melting so fast right now, scientists thought it was an error*. Slate. 2016.

6. S.B.Wallace. *Climatic change: are we on the brink of a pronounced global warming?* Science. 1975; 189(4201): p. 460 - 463.
7. Royal Society and US National Academy of Sciences. *Climate change - Evidence and causes: An overview from the Royal Society and the US National Academy of Sciences*. 2014.
8. J.Hansen, et al. *Global temperature change*. Proceedings of the National Academy of Sciences (PNAS). 2006; 103(39): p. 14288 - 14293.
9. Intergovernmental Panel on Climate Change (IPCC). *Climate change 2013: the physical science basis*. 2013.
10. Maria-Jose Viñas. *2016 Arctic Sea ice wintertime extent hits another record low*. National Aeronautics and Space Administration (NASA). 2016.
11. Josh K.Willis, Don P.Chambers, Chung-Yen Kuo, C.K.Shum. *Global sea level rise: Recent progress and challenges for the decade to come*. Oceanography. 2010; 23(4): p. 26 - 35.
12. Intergovernmental Panel on Climate Change (IPCC). *Climate change 2007: The physical science basis*. 2007.
13. Jorge L.Sarmiento, Nicolas Gruber. *Sinks for anthropogenic carbon*. Physics Today. 2002: p. 30 - 36.
14. David T.Allen, Vincent M.Torres, James Thomas, David W.Sullivan, Matthew Harrison, Al Hendler, Scott C.Herndon, Charles E.Kolb, Matthew P.Fraser, A.Daniel Hill, Brian K.Lamb, Jennifer Miskimins, Robert F.Sawyer, John H.Seinfeld. *Measurements of methane emissions at natural gas production sites in the United States*. Proceedings of the National Academy of Sciences (PNAS). 2013; 110(44): p. 17768 - 17773.
15. R.Henning. *A comparison of the contribution of various gases to the greenhouse effect*. Science. 1990; 248(4960): p. 1217 - 1219.
16. M.Harrison, T.Shires, J.Wessels, M.Cowgill. *Methane emissions from the natural gas industry. Volume 1: Executive summary*. US Environmental Protection Agency. 1996.
17. Edward J.Dlugokencky, Euan G.Nisbet, Rebecca Fisher, David Lowry. *Global atmospheric methane: budget, changes and dangers*. Philosophical Transactions of Royal Society A. 2011; 369: p. 2058 - 2072.

18. Intergovernmental Panel on Climate Change (IPCC). *Climate change 2014: Impacts, adaptation, and vulnerability*. 2014.
19. The Economist. *ETS, RIP? The failure to reform Europe's carbon market will reverberate round the world*. 2013.
20. Rob Bailey, Shane Tomlinson. *Post-Paris: Taking forward the global climate change deal*. Chatham House. 2016.
21. Morna Isaac, Detlef P.van Vuuren. *Modeling global residential sector energy demand for heating and air conditioning in the context of climate change*. Energy Policy. 2009; 37(2): p. 507 - 521.
22. Serene Cheong, Heesu Lee. *Drought breathes life into diesel in asia as farms get scorched*. Bloomberg. 2016.
23. International Energy Agency (IEA). *Global EV Outlook 2016 - Beyond one million electric cars*. 2016.
24. Tom Randall. *Here's how electric cars will cause the next oil crisis*. Bloomberg. 2016.
25. Pedro van Meurs. *Government fiscal strategies under low oil prices and climate change*. 2016.
26. McKinsey & Company. *Evolution - electric vehicles in Europe: gearing up for a new phase?* 2014.
27. IEA. *Energy and Climate change*. World Energy Outlook Special report. 2015.
28. Wood Mackenzie. *Carbon-constrained scenario*. Global Trend Service. 2015.
29. Mark Bolinger, Joachim Seel. *Utility-scale solar 2014 - An empirical analysis of project cost, performance, and pricing trend in the United States*. Lawrence Berkeley National Laboratory. 2015.
30. Wood Mackenzie. *Is solar - the next shale?* 2015.
31. Rakteem Katakey. *Shell wins investor approval to buy BG, sealing biggest deal*. Bloomberg. 2016.
32. The Economist. *Nodding donkeys - Some oil majors are still ducking the issue of global warming*. 2015.
33. Coral Davenport. *E.P.A. Methane leak rules take aim at climate change*. New York Times. 2016.
34. Carey Bylin, Zachary Schaffer, Vivek Goel, Donald Robinson, Alexandre N.Campos, Fernando Borensztein. *Designing the ideal offshore platform methane mitigation strategy*. SPE International Conference on Health, Safety and Environment in Oil and Gas Exploration and Production, Rio de Janeiro, Brazil. 12 - 14 April, 2010.
35. Spencer Dale. *New economics of oil*. BP. Society of Business Economists Annual Conference, London. 13 October 2015.
36. Stephen Foley. *Even oil barons are giving up on fossil fuels*. Financial Times. 2016.
37. Mark Carney. *Breaking the tragedy of the horizon - climate change and financial stability*. Bank of England. Lloyd's of London. 2015.
38. Paul Stevens. *International oil companies: The death of the old business model*. Chatham House. 2016.
39. Terry Macalister. *Shell creates green energy division to invest in wind power*. The Guardian. 2016.
40. Michael Stothard. *Total continues renewable energy charge with Saft battery deal*. Financial Times. 2016.

AN OVERVIEW OF VIETNAM'S OIL AND GAS INDUSTRY

Le Viet Trung¹, Tran Quoc Viet², Pham Van Chat³

¹Vietnam Petroleum Institute

²Vietnam Oil and Gas Group

³Petrovietnam Petrochemical and Textile Fiber JSC

Email: trunglv@vpi.pvn.vn

Summary

The paper presents an in-depth analysis and evaluation of the role of the oil and gas industry, which is represented by the Vietnam National Oil and Gas Group (Petrovietnam), in the national economy, and analyses the changes and development of the oil and gas sector in recent years. The analysis covers most of the activities that contribute to the development of Vietnam's economy and Petrovietnam's activities in the oil and gas value chain.

Key words: Oil and gas, Petrovietnam.

1. Introduction

According to BP's statistics, Vietnam ranked 28th among 52 countries that have oil and gas potential in the world. By the end of 2015, the proven crude oil reserves of Vietnam were approximately 4.4 billion barrels and ranked first place in Southeast Asia, while the proven gas reserves were about 0.6 trillion cubic metres (Tcm) and ranked the third place in the South East Asia (after Indonesia and Malaysia) [1].

Since the first oil at Bach Ho field in 1986, the Vietnam National Oil and Gas Group (Petrovietnam) - after nearly three decades - has made significant progress and strived to be the backbone of the national economy. Petrovietnam also plays an important part in the process of industrialisation and modernisation of the country, contributing averagely about 25 - 30% of the total annual state budget revenues. Petrovietnam has uplifted Vietnam's position in the community of oil producing countries and contributed to raising Vietnam's international reputation. So far, Petrovietnam has built an integrated oil and gas value chain, including exploration and production, processing and oil and gas services.

The paper presents an in-depth analysis and evaluation of the role of the oil and gas industry, which is represented by Petrovietnam, in the national economy, and analyses the changes and development of the oil and gas sector in recent years. The analysis covers most of the activities that contribute to the development of Vietnam's economy and Petrovietnam's activities along the oil and gas value chain.

2. The role of oil and gas industry in Vietnam's economy

The oil and gas industry, including the Vietnam National Oil and Gas Group (Petrovietnam) and the

Vietnam National Petroleum Group (Petrolimex), plays an important role in Vietnam's economy and has major impacts on the development of Vietnam. The oil and gas industry in general and Petrovietnam in particular contribute significantly to the state budget revenues and have a high proportion in Vietnam's export. Moreover, this sector attracts foreign investors to bring capital and modern technology to Vietnam.

2.1. Contribution to GDP and the State budget

Over the years, Petrovietnam has always maintained the leading role in the national economy. While the state-owned enterprises contribute about 42% of GDP, Petrovietnam separately accounts for 16 - 18% of GDP, the highest level in comparison with the whole country in the period from 2008 to 2015 (Table 1).

After the first gasoline by Petrovietnam's first refinery (Dung Quat), crude oil revenues, in the 2009-2013 period, now only contributed an average of 13.6% of total annual state budget. In the previous years, crude oil revenues always brought more than 20% of total state budget revenues while revenues from all state-owned enterprises (excluding the oil and gas industry) accounted for only about 15 - 16%. Moreover, the budget contribution of Petrovietnam is much higher than the contribution made by all foreign-invested and private enterprises. By the end of 2014 and early 2015, when the world was affected by the fall in oil prices, revenues from crude oil still accounted for an important proportion in the national economy. As reported by the General Statistics Office, crude oil revenues reached VND 98.1 trillion, contributing 12.1% of the total state budget in 2014. However, the figure for 2015 reduced significantly to VND 62.4 trillion because of the slump in the crude

oil price and the contribution was only 7.1% of the total state budget in the year.

In terms of consolidated revenues: From the end of 2007 and particularly in 2008, the world has witnessed the unpredictable volatility of crude oil prices, from USD 90/barrel by the end of 2007 to above USD 147/barrel in July 2008, and followed by an unexpectedly rapid decline to nearly USD 50/barrel at the end of 2008 - almost 70% compared to the peak. From the beginning of 2009, oil prices have fluctuated and averaged USD 64/barrel. However, in the wake of financial crisis, the global economic downturn and the sharp fall in oil prices, the consolidated revenue of Petrovietnam in 2009 still reached VND 137 trillion, 8% higher as compared to 2008. In 2010, Petrovietnam made great progress to achieve consolidated sales of VND 235 trillion - an uncommonly high rate in the context of the world economic recession, and equivalent to 24% of GDP. By the end of 2012, the consolidated revenues reached VND 363 trillion, increasing 12% as compared with the revenues in 2011. The state budget contribution was VND 186.3 trillion, which accounted for 24.4% of the total revenue of the country. In 2013, consolidated revenues of Petrovietnam increased by 7% compared to the revenues in 2012, amounting to VND 390 trillion and its state budget contribution increased by VND 9,100 billion. As a result of the plunge in crude oil price, the consolidated revenues in 2014 and 2015 were down 6% and 15% to VND 366 trillion and VND 311 trillion, respectively. However, the contribution of Petrovietnam

to the state budget revenues was still quite high with VND 115.1 trillion in 2015.

2.2. Import-export turnover

Crude oil has a strategic position among the export products of Vietnam. Crude oil exporting is essential for Vietnam's economy because it provides the foreign currency needed for imports, international transactions, and also for paying foreign debts. This source of foreign currency also plays an important role in stabilisation of exchange rates, macro-economics adjustments and improvement of foreign currency liquidity for the national economy.

Since crude oil was first produced, it has always accounted for a large share of export value as compared to other major export products of Vietnam such as footwear, textiles and garments, and fisheries. Table 2 illustrates the shares of export value (expressed in percentage) of some major products of Vietnam in 2005 and in the period from 2008 to 2015.

In 2005, crude exporting accounted for 26.41% of Vietnam's total exports and reached USD 7.37 billion. In 2008, the figure was USD 10.36 billion, which was equivalent to 21.42% of total exports but then fell down to just only USD 3.806 billion in 2015 (or 2.34%). The data showed that crude oil exports dropped sharply from 2008 to 2015, and were particularly less than the previous period. There are two reasons for the decrease in crude oil export value in recent years. Firstly, it is the decline of production in large fields, especially Bach Ho

Table 1. Contribution of Petrovietnam to Vietnamese economy [2 - 9]

Year	2008	2009	2010	2011	2012	2013	2014	2015
Petrovietnam's consolidated revenue (trillion VND)	127.0	137.0	235.0	325.0	363.0	390.0	366.0	311.0
GDP (trillion VND)	1,477.7	1,700.5	1,980.8	2,537.5	2,978.2	3,139.6	3,937	4,192.9
Petrovietnam's contribution in GDP (%)	18.9	16.0	24.0	26.6	25.9	24.3	9.3	7.4
Petrovietnam's contribution to the State budget (trillion VND)	121.8	88.0	110.4	160.8	186.3	195.4	189.4	115.1
Petrovietnam's contribution to the State budget (%)	29.2	22.6	27.9	27.1	24.4	24.1	23.3	13.0
Contribution of crude oil revenue to the State budget (%)	24.0	12.9	14.4	11.5	18.3	12.1	12.1	7.1

Table 2. Export value of major products

Unit: %

Year	2005	2008	2009	2010	2011	2012	2013	2014	2015
Crude oil	26.41	21.42	14.56	9.37	10.36	9.70	7.21	4.79	2.34
Footwear	10.89	9.87	9.57	9.55	9.37	8.58	8.38	6.81	7.39
Textiles	17.10	18.87	21.31	20.90	18.91	17.04	17.90	13.84	13.93
Fisheries	9.79	9.33	10.00	9.36	8.75	7.20	6.68	5.24	4.06
Other	35.81	40.51	44.56	50.82	52.61	57.48	59.83	69.32	72.28
Total	100.00	100.00	100.00	100.00	100.00	100.00	100.00	100.00	100.00

(Source: 2011 and 2015 Statistical Yearbook)

field. Secondly, in 2009 Dung Quat Refinery went online and consumed a significant amount of domestic crude oil. Despite this, crude oil was still important in the total export value of the country.

2.3. Attracting foreign investment into Vietnam

The oil industry has a positive impact on attracting foreign investment into Vietnam. In the period from 1988 to 2014, many foreign oil companies from the United States, Japan, Russia, UK, Malaysia, Canada, and Australia have invested in the exploration and production sector in Vietnam, through different kinds of oil and gas contract. A total of 102 petroleum contracts have been signed, including 63 contracts which are currently valid. In the period from 1988 to 2012, the oil and gas sector only accounted for about 4.6% of the total number of foreign investment projects but brought more than 17% of total foreign investment (about USD 30.5 billion). Many big projects in the fields of gas, electricity, refining and petrochemical, and technical services have been brought onstream to fuel the national economy development and the industrialisation and modernisation of the country.

Currently, there are more than 40 international oil companies operating in the upstream, midstream and downstream sectors in Vietnam. Several major oil companies are co-operating with Petrovietnam, mainly in the upstream sector such as Chevron, ExxonMobil (US), KNOC (Korea), Gazprom (Russia), Petronas (Malaysia), PTTEP (Thailand), Talisman (formerly Canadian, now Spanish), Total and Neon Energy (France). Most of these companies have invested in the form of capital contributions with Petrovietnam to implement petroleum contracts. In addition, Petrovietnam and Gazprom established the Vietgazprom company to jointly explore oil and gas in Russia and Vietnam.

Beyond the role as the representative for the host country in managing the exploration and production of oil and gas, Petrovietnam is also an investor (equal to other foreign oil and gas companies) in most of domestic exploration and production projects. However, the participation percentage of Petrovietnam (typically 25 - 50%) and the time of capital investment may vary depending on the characteristics of each contract.

Petrovietnam has accessed and been transferred various types of modern technology as well as advanced management methods to apply to its corporate

governance. Petrovietnam's workforces are now able to manage large, important projects, or work independently in E&P activities, gas transportation and downstream projects (power plants, fertilizer plants, etc.). Petrovietnam is also considered a successful corporation in providing high quality oil and gas services, especially drilling services. This is an important step to help Petrovietnam and the country quickly integrate into the oil and gas community and the international economy.

3. Oil and gas exploration and production

3.1. Oil and gas exploration and production

Petrovietnam started oil and gas exploration and production activities in 1961, mainly with the help of the Soviet Union in the North of Vietnam. Following the renovation policy in 1986 and the Foreign Investment Law enacted in 1987, oil and gas exploration and production activities have been strongly deployed, especially on the continental shelf. Many companies have discovered oil and gas such as Total in the Northern Gulf, Shell in the Central Coast, ONGC and BP at the Nam Con Son basin.

At first, exploration activities were mainly conducted by foreign oil companies and Petrovietnam only made capital investment when there was commercial discovery. At present, Petrovietnam is able to conduct oil and gas exploration itself or in co-operation with foreign partners, not only in blocks near the shore but also in offshore and deep-water blocks. Thus, the annual oil and gas reserves of Petrovietnam always increase. In the period from 2010 to 2015, Petrovietnam's oil and gas reserves increased by 43, 35.6, 48.32, and 40.5 million tons of oil equivalent, successively.

Vietnam started gas production in 1981 (at Tien Hai C gas field in Thai Binh province), and has produced both oil and associated gas since 1986 (at Bach Ho field in the southern continental shelf). Since then, Vietnam has been included in the list of crude oil exporting countries in the world. By 31 December 2015, the entire petroleum industry has produced over 352.68 million tons of oil and 114.03 billion cubic metres (Bcm) of natural gas. Basement reservoirs account for 80% of oil reserves and production of Vietnam. In the period from 1986 to 2013, oil and gas production increased significantly. Oil production averaged over 16 million tons of oil/year or 0.5% of total global oil production. Gas production reached 7Bcm/year or 0.2% of total global gas production. In 2014 alone, 17.39 million tons of crude oil and 10.21Bcm of gas were

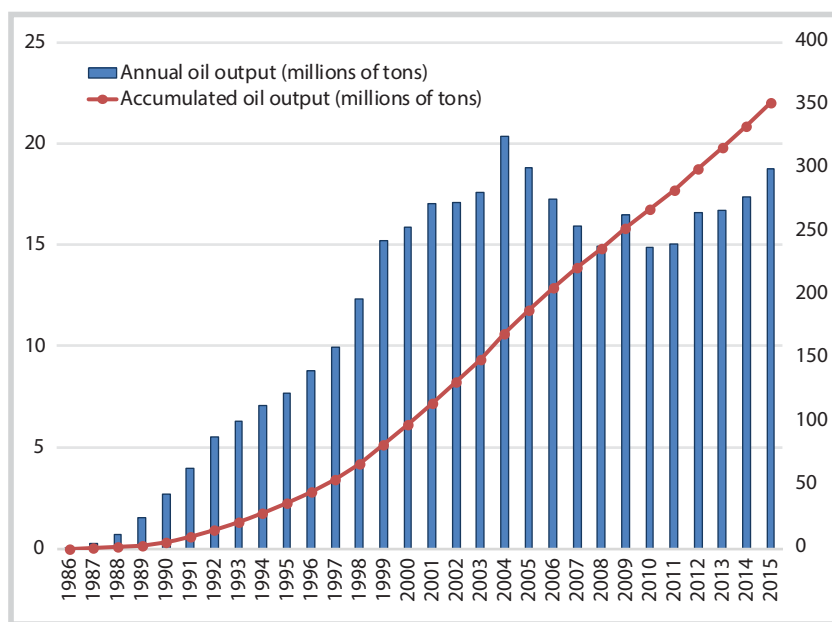

Figure 1. Annual crude oil production from 1986 - 2015

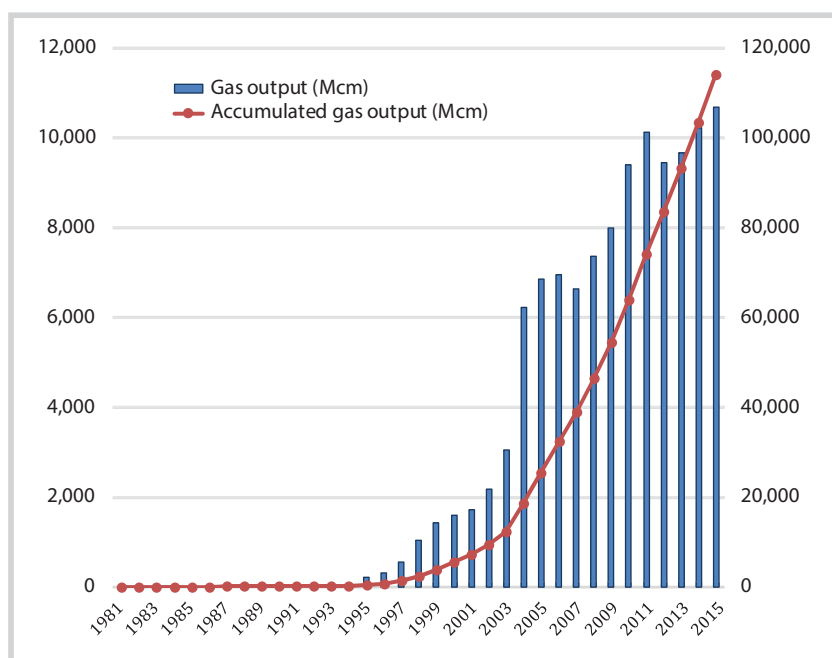

Figure 2. Annual natural gas production from 1981 - 2015

produced by Petrovietnam. The figures rose slightly in 2015 to 18.75 million tons of crude oil and 10.67Bcm of gas.

Figure 1 shows that crude oil production had increased gradually since 1986 and peaked in 2004 at over 20 million tons/year. However, production started to decrease in 2005 because production level from major fields such as Bach Ho or Rong fell sharply while production of small fields could not offset this decline. Between 2006 and 2010, 14 small fields were put into production, but production output only increased slightly in 2009 and then continued to fall. From 2011 to 2015, 36 oil and gas fields and structures were put into production, of which 26 fields/structures are at home and 10 abroad. Prospecting and exploration activities are at present conducted in offshore

and deepwater areas, which is costly and time-consuming, and recent oil and gas discoveries are mainly small fields. In its strategy, Petrovietnam will try to produce 5 - 14 million tons/year of crude oil and condensate for the period 2016 - 2025.

Figure 2 shows Petrovietnam’s gas production from 1981 to 2015. From 1986 to 1997, natural gas production did not increase significantly and then a strong surge has been witnessed in the period from 1997 to present. According to statistics from Petrovietnam, by December 2015, total natural gas production is over 111.88Bcm. Specially, the amount of gas produced in 2015 alone reached a record high of 10.67Bcm - the highest level since 1981. For the period 2016 - 2025, Petrovietnam sets its target to produce 11 - 19 Bcm/year of gas.

3.2. Oil and gas fields in Vietnam

By the end of 2013, there were 9 contracts in development stage and 13 contracts in production stage (from 14 oil fields/cluster of fields and 6 gas fields/cluster of fields) in the country. Production of the whole industry has exceeded 268.31 million tons of crude oil, including 189.9 million tons from Vietsovpetro and 78.3 million tons from PVEP. Particularly, in 2013, crude oil production was 15.25 million tons, and gas production amounted to 9.75Bcm; in 2014, production reached 17.39 million tons of crude oil and 10.21Bcm of gas. Oil and gas production continued to climb in 2015 to 18.75 million tons and 10.67Bcm, respectively.

Through development and production activities, Petrovietnam’s technical capability has been developed and Petrovietnam is nowadays capable of operating development and production activities in the deep water and offshore areas. Especially, Petrovietnam has discovered and successfully produced

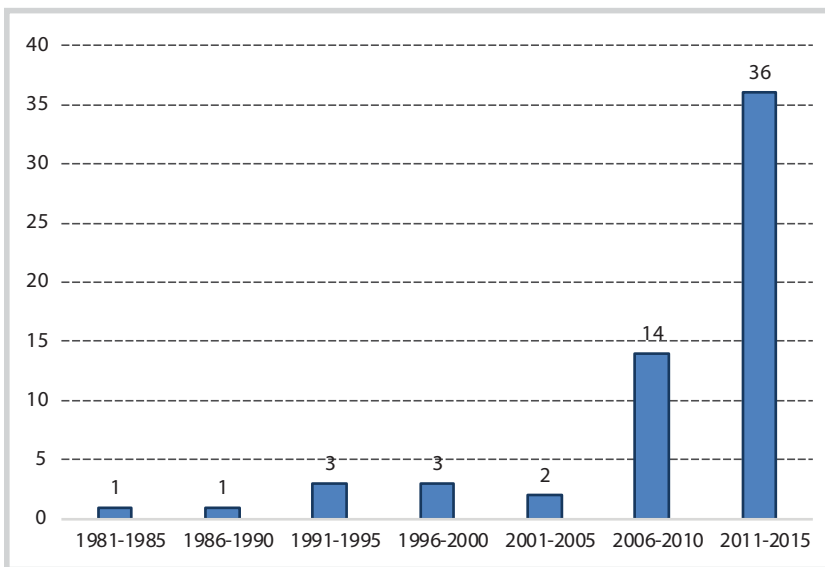

Figure 3. Number of fields put into production in 5-year periods

crude oil from pre-Tertiary basement reservoirs. This opened a new chapter for oil and gas exploration and production activities in the continental shelf of Vietnam. Furthermore, it has made important contributions to petroleum science and technology as well as petroleum production technology for basement reservoirs of the world.

In the past few years, Vietnam has made effort to speed up exploration and field development projects. From 2011 to 2015, 36 new fields and structures were put into operation. Of which in 2011 there were 3 domestic fields (Dai Hung phase 2, Te Giac Trang and Chim Sao) and 2 overseas fields (Visovoye and Dana). In 2012, there were 7 new fields and structures, including H4 platform at Te Giac Trang field, Gau Trang, Su Tu Trang and Lan Do (domestic fields) and West Khosedayuskoye, Junin 2, and Nagumanovskoye (overseas fields). The number of new fields rose to 9 each year in 2013 and 2014. The figure for 2015 plunged to 4 fields, including: Thai Binh gas field, H5 platform at Te Giac Trang field, Tho Trang 2 platform (domestic) and Bir Seba Block 433a - 416b (overseas). Besides exploration activities, Petrovietnam also participated in the field development phase of Su Tu Trang, Dai Hung (Phase 2), Hai Thach - Moc Tinh (Block 05-2 and 05-3), Te Giac Trang (Block 16-1), Hai Su Trang - Hai Su Den (Block 15-2/01), Chim Sao, Dua (Block 12W). However, these oil fields only possess small reserves (the largest among the newly discovered oil fields is Su Tu Den with about 100 million tons, only one-third of Bach Ho).

3.3. Petroleum contract types

Vietnam has signed oil and gas contracts in various forms, namely production sharing contract (PSC), petroleum contract (PC - with the participation of Joint Operating Company - JOC), business co-operation contract (BCC), and joint venture (JV). The majority of oil and gas exploration and production acres of the signed contracts are located in three basins: Nam Con Son (32), Song Hong (23) and Cuu Long (19). Big foreign oil companies such as ExxonMobil, Shell, and Chevron are operating

in Vietnam in the form of PSC contract with Petrovietnam - the representative of the host country. With this type of contract, Petrovietnam may reduce the risk when there is no commercial discovery and have the opportunity to learn the high technologies applied in the petroleum industry, train the workforces and have significant contribution to the state budget. In the PSC contracts, the parties will appoint an operator - mostly a foreign oil company, whereas in the PC contract, Petrovietnam will take part in field management together with foreign oil companies through a joint operating company (JOC). BCC is also a production sharing contract but differs in the operating and managing subject, in this case the party which contributes more shares will be the operator. By the end of 2013, Vietnam had about 100 oil and gas contracts, of which 90% were PSC contracts and the others were JOC and BCC. There was only one contract signed in 2015 which increased the total number of contracts during the 2011 - 2015 period to 34 contracts.

4. Oil and gas processing

Oil and gas processing is one of the core sectors. It plays an important role in the development of Vietnam's oil and gas industry with the purposes of enhancing the value of oil and gas resources, saving foreign currency, contributing to ensuring energy security, promoting national industrialisation and modernisation and improving the competitive position of Vietnam's oil and gas industry in the world.

Construction of fertilizer plants started in 2001 and Phu My - the first fertilizer plant of Petrovietnam went into operation in 2004 (with a capacity of 800,000 tons/year). Next, the Ca Mau Fertilizer Plant with a similar capacity came online in 2012.

Table 3. Production capacity and market supply of Petrovietnam's main petroleum products

Source: EMC

Product	Production capacity (thousand tons)						Domestic demand (thousand tons)						% meet Domestic demand					
	2010	2011	2012	2013	2014	2015	2010	2011	2012	2013	2014	2015	2010	2011	2012	2013	2014	2015 (Expected)
LPG	552	578	569	707	672	750	1,115	1,125	1,367	1,465	1,483	1,701	49.5	50.0	41.6	48.0	45.0	44.0
Gasoline	1,820	1,840	2,029	2,232	1,790	1,896	4,502	4,783	5,034	5,243	5,457	5,632	40.0	38.0	40.0	43.0	33.0	33.7
Diesel oil	2,801	2,949	3,251	3,576	2,869	3,037	7,297	7,606	8,006	8,395	8,811	9,284	38.0	39.0	41.0	43.0	33.0	32.7
Jet A1	106	107	118	130	104	110	910	967	1,018	1,078	1,151	1,248	12.0	11.0	12.0	12.0	9.0	8.9
Fuel oil	178	180	199	219	176	186	2,071	2,200	2,314	2,395	2,341	2,404	9.0	8.0	9.0	9.0	8.0	7.8
Urea	807	920	1,724	1,602	1,525	1,600	1,928	2,175	2,042	2,105	2,200	2,874	41.9	42.3	84.4	76.0	69.0	55.7

Table 4. Petrovietnam's gas consumption in 2011 - 2015 [10 - 13]

	Unit	2011	2012	2013	2014	2015
Dry gas	Million m ³	8,533	9,175	9,469	9,960	10,430
LPG	Thousand tons	1,166	1,027	1,061	1,086	1,320
Condensate	Thousand tons	58	61	62	59.5	59.8

The year of 2009 marked an important step in oil and gas processing activities of Petrovietnam when the first oil refinery of Vietnam - Dung Quat Refinery - went into operation with the capacity of 6.5 million tons/year. Dung Quat Refinery began commissioning in February 2009 and had commercial products from May 2010. Since then, Petrovietnam has had complete activities of the oil and gas value chain, from exploration to processing. Currently, the Nghi Son Refinery and Petrochemical Complex with the capacity of 10 million tons/year is being constructed and is expected to come online in 2017. With the new capacity added, Petrovietnam can meet about 60% of domestic demand. Besides, Petrovietnam has been implementing a series of new projects in oil refining, petrochemical, bio-fuels and plans to expand and upgrade the Dung Quat Refinery in order to meet the demand for petroleum, feedstocks and petrochemical products of the country.

With successful projects in the processing sector, Petrovietnam has the capacity to produce essential products such as gasoline, fertilizer, plastic resins and other chemical products with economic value of tens of trillions VND, thus helping Vietnam move from import dependent to producing for domestic demand and in the future for export. By 2015, the production capacity in oil and gas processing is expected to increase substantially to meet most of the domestic demand with export orientations in the future (Table 3). However, the domestic petroleum products are facing great competition from imported products.

5. Gas industry

With the aim to optimise the gas value chain, Petrovietnam has invested in the gas industry since

the 1990s to develop an integrated gas business from collecting, import, transportation, storage, processing, distribution, and trading. The National Gas Pipeline System Plan approved by the government also foresees possible connection with the gas pipelines of ASEAN countries. Currently, Vietnam has three main gas transportation and distribution systems: Nam Con Son gas transportation and distribution system, PM3-Ca Mau gas transportation system and Cuu Long gas transportation and distribution system [10].

Besides gas pipeline systems, Thi Vai Refrigerated Storage (with a storage capacity of 60,000 tons of cold LPG) invested by Petrovietnam Gas Joint Stock Corporation (PV GAS) has been completed and began operation. Thi Vai storage system includes: wharf technology system for cold LPG import; LPG off-loading system; storage system, cooling system, pressurised tank system, heating system, pump system, LPG vapour compressors, and other auxiliary systems. This is the largest cold LPG depot in Vietnam that allows PV GAS to store a big amount of LPG, increase LPG supply in long term, stabilise domestic supply, and contribute to national energy security.

Gas consumption systems include Dinh Co Gas Processing factory and LPG importing and storage systems. They have been developed and operated safely in order to provide a stable source of gas for industrial development including gas power plants of Petrovietnam and EVN, the BOT investors, the fertilizer plants and the low-pressure gas consumers. Gas fired power plants produce over 39 billion kWh of electricity per year and account for 33% of national electricity production. Gas is also supplied to produce over 1.5 million tons of nitrogen per year, accounting for 70 - 75% of the domestic demand. LPG and

CNG are also imported and distributed to industrial and household consumers in the country in order to contribute to ensuring the national energy and food security. In its strategy, Petrovietnam will maintain to supply to 100% of market share for dry gas and to increase the market share of LPG to at least 70% of total domestic market.

6. Power industry transportation

Besides the gas industry, Petrovietnam has also invested in building power plants to meet the rising demand for power needed for the country’s economic development. Although this is a new field, Petrovietnam has achieved initial success. From 2011 to 2015, 5 power plants came online including Nhon Trach 2 Thermal Power Plant (750MW), Phu Quy Wind Power Plant (6MW), Hua Na Hydro-power Plant (180MW), Dakdrinh Hydro-power Plant (125MW) and especially in 2015, Vung Ang 1 Thermal Power Plant (1,200MW). Vung Ang 1 is the first coal-fired power plant of Petrovietnam and also the largest capacity thermal power plant of the country. By the end of 2015, the total capacity of Petrovietnam’s power plants was 4,214MW. Total electricity supplied by Petrovietnam to the national grid in the 5-year period from 2011 to 2015 reached 83.554 billion kWh (with an average growth rate of 12.1%/year). Particularly in 2015, Petrovietnam’s power production amounted to 21.98 billion kWh, up 31.7% from 16.69 billion kWh in 2014. Petrovietnam is striving to develop a power industry with the target of producing 15% of the national electricity production by 2020. At the same time, Petrovietnam is preparing the infrastructure, technology and human resources to participate in the wholesale competitive electricity market.

7. Oil and gas services

Oil and gas services is one of Petrovietnam’s important business domains. Petrovietnam’s oil and gas services are expanding both in scale and technology to support domestic and overseas oil and gas projects. Petrovietnam provides diverse services, including geophysical surveys, drilling services, oil and gas wells services, export, import

and supply of materials and equipment for the petroleum sector; import, export and trading of crude oil and oil products; transport, storage, supply and distribution of petroleum products; operation and maintenance of oil and gas projects/structures; handling of oil spill; designing, construction and installation of oil, gas, power and civil construction projects; shipping and logistic services; provision of technical manpower, tourism, and hotels, etc. Besides, Petrovietnam’s subsidiaries also provide insurance services, credit arrangement for investment projects, capital raising, corporate credit, financial services and securities. In addition, Petrovietnam can provide scientific research and training services such as consulting, research and technology transfer, geophysical data processing services, etc.

The wide range of oil and gas services has significantly contributed to the total revenue of Petrovietnam. Total revenue from oil and gas services from 2011 to 2015 was VND 1,114 trillion, accounting for 31.7% of Petrovietnam’s total revenue. The growth of oil and gas service sector has been relatively fast and stable and its revenue reached VND 207.8 trillion in 2011, VND 234 trillion in 2012, VND 236.3 trillion in 2013 and VND 240.7 trillion in 2014. In 2015, the decline in oil prices which forced oil and gas operators to cut jobs and service prices, along with the difficulties of competition, barriers to trade, and tariffs, has lowered revenue from oil and gas services to VND 196 trillion (down 19% compared to 2014). However, the average growth rate in the period from 2011 to 2015 was still 4%/year.

8. Conclusion

Vietnam is a country with oil and gas resources and the oil and gas industry has made important contribution to the national economy. The industry brings over 20% of total state budget revenues and contributes 16 - 18% of GDP in recent years. Crude oil is always one of four products of Vietnam that have the highest export value. Before 2005, crude oil contributed up to 23% of export turnover and even today when other industries (such as

Table 5. Business performance of some major service companies [4]

Company	Return on equity (%)					
	2011	2012	2013	2014	2015	5-year average
PTSC	30.6	20.8	23.4	20.7	13.3	22
PV Drilling	18.8	20.0	23.7	23.8	13.3	20
Petrosetco	25.3	17.3	15.9	18.2	13.0	18
DMC	25.0	37.2	18.7	36.3	16.0	27
PVE	36.8	4.3	5.2	8.4	10.3	13

the petrochemical industry) are more developed, crude oil still maintains an average contribution rate of 7 - 8% of annual export turnover. The oil and gas industry attracts major foreign investment in oil and gas exploration and production activities. It not only helps Vietnam resolve difficulties in investment funds but also improves management skills and technology in the industry, helping it strive to be able to compete with international oil companies and make investments abroad.

Vietnam's oil and gas industry which is represented by Petrovietnam has made great progress in science and technologies, especially petrochemical technologies. Dung Quat Refinery's first batch of products in 2009 marked the comprehensive development of the oil and gas industry in Vietnam. Today, the oil and gas industry of Vietnam has developed an integrated oil and gas value chain, including oil and gas exploration and production, gas-power industry, oil and gas processing, and oil and gas technical services, with the core sector being oil and gas exploration and production. In the near future, Vietnam's oil and gas industry continues to play an important role in the national economy and Petrovietnam continues to supply substantial amounts of petrochemical products, fertilizer and electricity to the domestic market.

The oil and gas industry's goal is continuing to make major contribution to the GDP and the national budget. In 2016, Petrovietnam is expected to increase oil and gas reserves to 16 - 20 million tons of oil equivalent and produce 5,690 thousand tons of petroleum products, striving to meet 80% of domestic demand. In the near future, Petrovietnam should speed up exploration activities in order to discover more small fields to offset the decline of major oil fields. For that purpose, Petrovietnam needs more capital investment for exploration, especially in the oil and gas potential areas of the country. On the other hand, the recent discovery of large gas fields, such as Ca Voi Xanh in the offshore of Central Vietnam, is expected to boost the gas industry's development in the near future (expectedly after 2020).

To maintain the momentum, the oil and gas industry should identify and improve weaknesses in production organisation, investment management, administration and development of human resources, especially highly-qualified workforce. Simultaneously, the decrease in

oil prices recently has caused significant impact to the oil and gas industry in general and Petrovietnam in particular. This is the time to review and supplement the development strategy, including point of view, orientation and development goals towards adapting to the rapid change of the oil and gas industry. This is also the period to prioritise the efficiency of the whole oil and gas chain and to enhance the operational capacity of the entire system. These are the decisive factors for the petroleum industry to maintain its dominant position and the sustainable development of Vietnam's oil and gas industry in the process of international integration.

Reference

1. BP. *BP statistical review of world energy (65th edition)*. 2016.
2. General Statistics Office (GSO). *An overview of export value in 2014*. 2014.
3. Ministry of Finance (MOF). *Annual state budget report*. 2015.
4. Petrovietnam. *Summary of 2015 performance and 2016 deployment plan*. 2016.
5. Petrovietnam. *Summary of 2014 performance and 2015 deployment plan*. 2015.
6. Petrovietnam. *Summary of 2013 performance and 2014 deployment plan*. 2014.
7. Petrovietnam. *Summary of 2012 performance and 2013 deployment plan*. 2013.
8. Petrovietnam. *Annual Reports*. 2011 - 2013.
9. Petrovietnam. *Resolution No. 7862/NQ-DKVN dated 1 September 2010 regarding "Approval of Petrovietnam's accelerating development strategy to 2015, vision to 2025"*. 2010.
10. PV GAS. *Annual report*. 2013
11. IHS. *National oil company strategies service*. 2015.
12. Petrovietnam. *Vietnam oil and gas geology and resource*. Science and Technology Publishing. 2007.
13. PV GAS. *Gas transportation and distribution*. 2015.

Vietnam, Russia seek to facilitate oil and gas co-operation

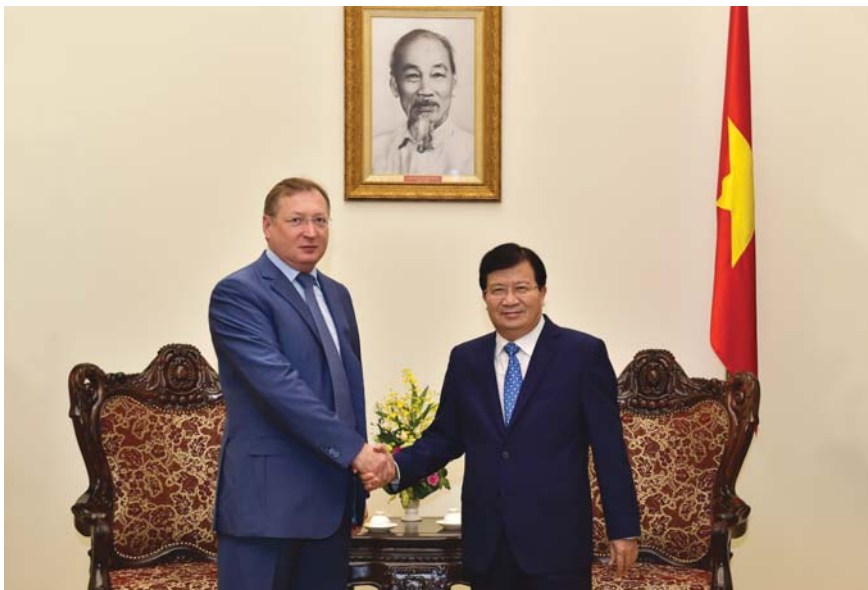

Deputy Prime Minister Trinh Dinh Dung received Mr. Sergey Kudryashov, General Director of Zarubezhneft. Photo: Nhat Bac

Deputy Prime Minister Trinh Dinh Dung made the statement at a reception for Mr. Sergey Kudryashov, General Director of Russia's Zarubezhneft oil and gas group, on 27 October in Ha Noi. He highly appreciated Vietnam-Russia co-operation in the field of oil and gas over the past years, which, he said, was one of the major and

effective pillars in bilateral relations, generating huge revenues for the two countries' budgets.

Highlighting the effective co-operation projects between the Vietnam National Oil and Gas Group (Petrovietnam) and Zarubezhneft, including Vietsovetpetro (in Vietnam) and Rusvietpetro (in Russia),

Deputy Prime Minister Trinh Dinh Dung asked the two groups to seek measures to reduce costs and enhance the operational efficiency of Vietsovetpetro and Rusvietpetro joint ventures, and exert greater efforts to make optimal use of the existing oil fields as well as search for new ones.

For his part, Mr. Sergey Kudryashov thanked the Vietnamese and Russian governments for closely directing the removal of difficulties for oil and gas joint ventures between the two sides. On the occasion, he also asked the Deputy Prime Minister to instruct relevant ministries and sectors to remove a number of existing obstacles.

Deputy Prime Minister Trinh Dinh Dung assigned the Ministry of Industry and Trade and Petrovietnam to work with Zarubezhneft to handle the hindrances in the spirit of creating favourable conditions for oil and gas companies of the two countries to strengthen bilateral co-operation.

Xuan Tuyen

Ham Rong - Thai Binh gas collection and distribution system: Gas consumption in 2016 estimated at over 140 million m³

As of 17 October 2016, the Ham Rong - Thai Binh gas collection and distribution system has supplied 106.52 million m³ of gas, equivalent to 100.5% of its yearly plan for 2016. With the current level of gas consumption, the system is forecasted to distribute over 140 million m³ of gas to customers in the whole year, equal to 132.33% of its plan for 2016. The completion of the 2016 plan 75 days earlier than schedule is a recognition of the efforts made by the Petrovietnam Gas South East Transmission Company's officials and employees.

The Ham Rong and Thai Binh gas collection and distribution system for the first time produced natural gas offshore Song Hong basin and transported to the land. This is a series of projects with the total investment of VND 3,236 trillion, including the "gas collection and distribution system of Ham Rong and Thai Binh fields, Blocks 102 & 106, phase 1" invested by PV GAS with



A facility of the Ham Rong - Thai Binh gas system. Photo: PV GAS

the amount of VND 1,925 billion (USD 91.7 million) for phase 1 and the "low pressure gas distribution system for Tien Hai-Thai Binh Industrial Zone" invested by PV GAS D with the amount of VND 1,311 billion (USD 62.11 million).

Khanh Hoang

Contract signed for Dai Hung gas processing services on Thien Ung platform



Vietsovpetro's General Director Tu Thanh Nghia and PVEP's President and CEO Ngo Huu Hai signed the contract for Dai Hung gas processing service on Thien Ung platform. Photo: PVEP

On 7 October 2016 in Ba Ria - Vung Tau province, Vietsovpetro Joint Venture signed the contract for Dai Hung gas processing services on Thien Ung platform with the Petrovietnam Exploration Production Corporation (PVEP); and also signed the contract for operational and maintenance services for the Dai Hung gas compression system on Thien Ung platform with the PVEP Domestic Operating Company (PVEP - POC).

Deploying the plans for Thien Ung field development and gathering

gas from Dai Hung field, Vietsovpetro has successfully carried out the design, procurement, construction, installation and commissioning for the topside of Thien Ung platform. Among these, Dai Hung compressor system is one of the important items of the overall project with the target to receive the first gas expected in November 2016.

Besides producing products from Thien Ung field, Thien Ung platform also receives, compresses and processes the associated gas from Dai Hung field, then transports

products from Thien Ung and Dai Hung fields through Nam Con Son 2 pipeline to Bach Ho field for further processing before transporting to Dinh Co Gas Processing Plant. The contract to provide operational and maintenance services for the Dai Hung gas compression system and the Dai Hung gas processing services on the Thien Ung platform was signed for an initial duration of 10 years. The General Director of Vietsovpetro assigned the Oil and Gas Production Division, the unit directly operating the Thien Ung platform, to implement and manage the contract.

At the signing ceremony, Chairman of the Board of Directors of Petrovietnam Nguyen Quoc Khanh highly appreciated the co-operation of Vietsovpetro and PVEP in recent years and confirmed the importance of enhanced utilisation of internal services in the difficult period due to oil price slump. The Petrovietnam leader believed that Vietsovpetro and PVEP will continue to further co-operation in oil and gas exploration and operation of oil and gas fields in Vietnam and in other countries.

Manh Hoa

Investment quality and progress to be ensured in the construction of oil and gas structures

On 18 October 2016 in Ba Ria - Vung Tau province, Petrovietnam held a conference on the management and implementation of power projects and the design and construction of oil and gas structures.

Chairman of the Board of Directors of Petrovietnam Nguyen Quoc Khanh required the units in the field of oil and gas design and construction to continue to improve the management and implementation model of EPC contracts

and projects; and gradually master the detailed designing work so as to be able to procure materials and equipment directly from suppliers, thus saving time and avoiding being dependent on intermediate suppliers and subcontractors. For the power projects management and implementation, the Petrovietnam leader requested the units to ensure the quality and progress of construction of the thermal power plants such as Thai Binh 2, Long Phu 1, and Song Hau 1.

Ngoc Anh

EVN TO REPLACE PVN AS THE INVESTOR OF QUANG TRACH 1 COAL-FIRED POWER PLANT

The Prime Minister has assigned the Vietnam Electricity (EVN) to replace the Vietnam Oil and Gas Group as the investor of the Quang Trach 1 Coal-fired Power Plant project under the Quang Trach Power Centre. The Ministry of Industry and Trade has been assigned to instruct Petrovietnam and EVN to complete the transfer procedures for the project in accordance with the law, ensuring the progress and avoiding wastefulness and loss during the transfer process.

Ngoc Phuong

Aluminum sacrificial anode proposed for addition to the list of indigenous products

On 12 October 2016, the delegation of the Ministry of Industry and Trade (MOIT) worked with the Vietnam Petroleum Institute to examine the aluminum sacrificial anode production facilities at the Centre for Technology Application and Transfer (CTAT) of the Vietnam Petroleum Institute.

After being briefed on the technical specification of the product and visiting the laboratories where the products are manufactured and their quality tested, the MOIT delegation highly appreciated that the aluminum sacrificial anode manufactured by the Vietnam Petroleum Institute had met the criteria for quality standards and would be possible to satisfy the market demand and the percentage of domestic production value (45%).

Aluminum sacrificial anode is the product successfully researched



The MOIT delegation worked with the Vietnam Petroleum Institute. Photo: Hong Ngoc

and manufactured by the Centre for Technology Application and Transfer (CTAT) - Vietnam Petroleum Institute. The product has been tested and evaluated by the Vietnam Quality Assurance and Testing Centre (Quatest 1) as having good quality, satisfying the domestic and international standards, and having the quality equivalent to imported products.

This is the first Vietnamese prod-

uct that was tested and accorded the international quality certification. It satisfied the strict requirements under the quality certification of the international accreditation organisation Det Norske Veritas (DNV). The aluminum sacrificial anode product has been used effectively to protect pipelines and equipments of oil and gas constructions against corrosion.

Hong Ngoc

Danan Block project to be relaunched

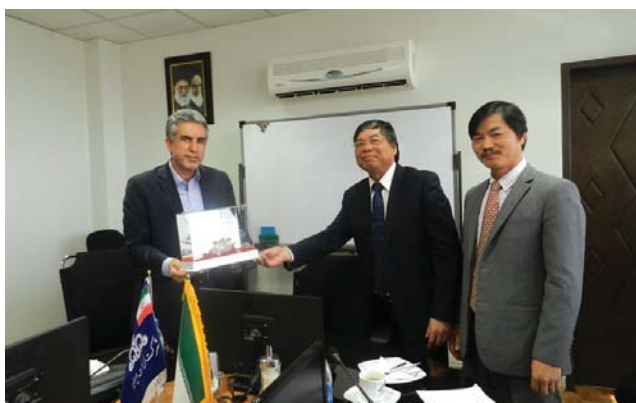

PVEP's leader at the meeting with the National Iranian Oil Company. Photo: PVEP

On 16 - 20 October 2016, Dr. Hoang Ngoc Dang, Chairman of the Board of Directors of the Petrovietnam Exploration Production Corporation (PVEP), attended the Iranian Petroleum and Energy Club Congress and Exhibition (IPEC) in Iran, and worked with the National Iranian Oil Company (NIOC) and its Exploration Directorate (NIOC ED) on the relaunching of Danan Block project.

Iran's Deputy Minister of Petroleum and Managing Director of NIOC Ali Kardor and General Director of NIOC ED Seyed Saleh Hendi said they were ready to create all conditions for PVEP to continue the Danan Block project. With the aim of relaunching the project in January 2017, the parties discussed and agreed to extend the exploration phase for PVEP to have enough time to fulfil the commitments under the contract.

At the technical meeting with NIOC ED, PVEP presented petroleum potential updates on the basis of 3D seismic data and reservoir testing information of the wells in Danan Block, especially well CK-6 at Cheshmeh Khosh field. At the same time, PVEP suggested some drilling locations and research programmes.

The NIOC ED leaders agreed with PVEP's assessment results and proposal about the locations of preliminary drilling wells, provided technical information to serve the detailed assessment of oil and gas potential of Danan Block and will participate and support PVEP's field works in this area in the near future.

Manh Hoa

PVFCO awarded "50 best listed companies in Vietnam" prize



PVFCO Chairman Le Cu Tan received the prize of Forbes Vietnam. Photo: PVFCO

On 29 September 2016, Forbes Vietnam magazine announced the 50 best listed companies in Vietnam stock market in the year. Forbes Vietnam conducts these evaluations based on the corporate brand and business

efficiency, the quality of corporate governance and sustainable development prospects.

The Petrovietnam Fertilizer and Chemicals Corporation (PVFCO) is the only member in the fertilizer industry to be honoured by the award

for 4 successive years. The ranking list recognises that PVFCO still achieves outstanding growth in spite of the challenging year 2015, and is considered to be the most capable enterprise in the domestic fertilizer industry thanks to its effective business with the 2015 turnover reaching VND 10,047 billion, profit after tax of VND 1,488 billion, dividend payout ratio of 40%, and potential growth in both the fields of fertilizer and chemical. DPM stock is evaluated to be in the attractive stock group for investors.

Besides PVFCO, 3 other Petrovietnam subsidiaries were also awarded the prize of Forbes Vietnam, namely Petrovietnam Gas Joint Stock Corporation (PV GAS), PVI Holdings, and Petrovietnam Power Nhon Trach 2 Joint Stock Company.

Bui Ha

Capacity of Ca Mau Fertilizer Plant raised to 110%

On 6 October 2016, Petrovietnam Ca Mau Fertilizer Joint Stock Company (PVCFC) announced it had increased the capacity of Ca Mau Fertilizer Plant to 110%. At the same time, PVCFC has traded and distributed other fertilizer products (such as DAP and potassium), focused investment on researching new products and improvement of business efficiency. In addition to urea granular products, N.Humate + TE in the brand of Dam Ca Mau, PVCFC will launch new products that help save fertilizer and increase crop yields.

In the first 9 months of 2016, PVCFC has produced and sold 570,000 tons of urea, achieving 99% of the plan. Its revenue reached



PVCFC has produced and sold 570,000 tons of urea. Photo: PVCFC

nearly VND 3,500 billion, equal to 85% of the plan, and its pre-tax profit amounted to nearly VND 400 billion, equal to 98% of the plan. In the remaining months of 2016, PVCFC

will concentrate on production to provide nearly 300,000 tons of fertilizers of different kinds in order to meet the fertilizer demand of the winter-spring crop.

Bui Ha



Production of major oil producing countries

Russian oil producers would struggle to co-ordinate an output reduction, hindered by insufficient storage capacity and the need for continuous pumping in the harsh permafrost of many oilfields and by a deep investment budget deficit. But for limiting the financial deterioration of the country, Russia has to maintain the production at a sufficient high level if the oil price does not really recover or recovers weakly toward USD 50/barrel.

Elsewhere in the former Soviet Union the production outlook is not quite as robust as it is in Russia. Kazakhstan and Azerbaijan, the biggest producers among ex-Soviet countries after Russia, are facing a natural decline in output as ageing fields deplete. The predicted output in 2016 of these countries is presented in Table 1.

Middle East region

Despite the probable OPEC decision to cut supply, the Middle East output could rise again due to a multiple reason. Saudi Aramco's oil and gas rig count will remain steady throughout 2016. The heightened competition among OPEC and non-OPEC players could push Aramco to add more oil. The main increases this year will emanate from Iraq and Iran. If combined Iraqi and Kurdish (the Autonomous Kurdistan Regional Government) production plans come good, the total output of this country will rise to 4.4 - 4.5 million barrels/day (MMbpd) in 2016. Kuwait, Qatar, Oman, UAE, and Bahrain production remains flat in the year ahead (Table 2).

North America

US oil output surprised many people last year with its resilience in the face of low oil prices. This year, people

Table 1. 2016 FSU oil output (million barrels/day)

Country	End-2016
Russia	10.60
Kazakhstan	1.55
Azerbaijan	0.85
Turkmenistan	0.24
Uzbekistan	0.07
Total	13.31

Sources: Petroleum Economist

Table 2. Welling up: 2016 Middle East oil output (million barrels/day)

Country	End-2016
Bahrain	0.20
Iran	3.80
Iraq	4.50
Kuwait	2.70
Saudi Arabia	10.30
Qatar	0.66
Oman	0.97
UAE	2.90
Others	0.04
Total	26.07

Sources: Petroleum Economist

might be surprised at how far production falls. Few wells are profitable at oil prices around USD 30/barrel. Gulf of Mexico will help prop up output, but it all adds up to a year of declines. Crude production could fall by around 0.9 million barrels/day, from 9.3 million barrels/day at the end of 2015 to 8.4 million barrels/day by the end of 2016. It does not forget that the US is an oil net import country, therefore the low oil price brings more benefits for it than damages.

The National Energy Board (NEB) of Canada predicts overall Canadian oil output this year could be about 3.9 million barrels/day. Heavy oil will be fairly level. Although it fetches the lowest price - sometimes trading for just 50%

of WTI - it is also the lowest cost and hardest to turn off. Canadian companies such as Meg Energy, a thermal oil sand producer, have reported the 4th quarter production costs below USD 6.44/barrel, which are among the lowest in the industry. Conventional light oil output, by contrast, will fall off the table. The NEB expects conventional output will fall this year to 0.82 million barrels/day from 0.86 million barrels/day at the start of the year.

Latin American countries

After years of strong gains, Latin America's oil production will slip by about 1%, or around 120,000 barrels/day in 2016. Capital spending falls by around 25% this year, marking the second straight year of deep spending cuts. Columbia and Mexico lead production declines, while Brazil's oil industry is going through a corruption scandal and deep financial pain. Despite this unfavourable environment, total Brazilian crude output should rise due to the three new pre-salt projects which see first oil in 2016. Mexico is likely to see the largest decline. Pemex posted the 3rd quarter loss of USD 10 billion with plans to cut 2016 spending by 20% to USD 17 billion. It has long struggled with falling output, which will continue as investment slips. The reform process will eventually see private money flow into oilfields, helping to reverse the decline, but 2016 is a difficult year.

Columbia's heavy oilfields need constant investment and drilling to keep production growing. Exploration spending is expected to be around USD 0.7 billion, according to industry group ACP. Output falls around 0.9 million barrels/day (Table 3).

Asia

It appears that China's oil production probably peaked at one point in 2015, and will enter structural decline some time over the course of the months ahead. This is significant as the country is not just a major crude

importer, it is also the world's fifth-largest oil producer, trailing behind only the US, Russia, Saudi Arabia and Canada.

The country's domestic oil production was up 2.2% to 4.3 million barrels/day - or just under 5% of global supply - last year compared with 2014. It was the highest level on record and the culmination of a remarkably constant expansion averaging 1.5 - 2% every year over the past two decades. But growth has started to falter. The age of China's big oilfields - they were discovered in the 1960s and 1970s - means production can only be sustained with strong growth in capital expenditure. Average production costs for China's majors - CNPC, Sinopec, CNOOC - are higher than USD 40/barrel. Analysts expect 50,000 barrels/day to be shut down over the course of 2016, as low oil prices close marginal production in aging fields and exploration activities begin to slow.

In South East Asia, production is expected to remain fairly stable, as the bulk of output, stemming from onshore and shallow-water fields, remains relatively low in cost. Still, Indonesia missed its production target, set at 0.825 million barrels/day, again last year. If oil prices averages around USD 40/barrel, expect Indonesia to pump a little more 0.8 million barrels/day this year. Malaysia crude volumes will continue to climb as Shell ramps up production at its deep-water Gumusut-Kakap field, expected to pump 135,000 barrels/day at peak. Oilfields in the Gulf of Thailand, which operate at an average cost of USD 30 - 40/barrel, will maintain stable flows this year. Elsewhere, production from India's low-cost onshore and shallow-water fields should remain steady at around 0.89 million barrels/day (Table 4).

West Africa

Nigerian National Petroleum Corporation (NNPC), from March, replaces crude oil swap agreements with direct crude sales to refineries and the purchase of refined

Table 3. 2016 Predicted output (million barrels/day)

Country	End-2016
Argentina	0.525
Brazil	2.590
Colombia	0.950
Ecuador	0.525
Mexico	2.175
Venezuela	2.560
Total	9.325

Sources: Petroleum Economist

Table 4. 2016 Predicted output (million barrels/day)

Country	End-2016
China	4.124
Indonesia	0.810
India	0.890
Malaysia	0.690
Vietnam	0.305
Thailand	0.260
Total	7.079

Sources: Petroleum Economist

products directly - an effort to remove middlemen from the process. The change will take time to make any difference. Struggling for cash, Nigeria wants to boost oil production. At best, Nigerian output, which was 1.8 million barrels/day in December 2015, will be 1.9 million barrels/day at the end of 2016.

Angola's campaign to draw investors into its deep offshore developments over recent years means production from projects already under way will bring an output increase. However, international oil companies say Angola will struggle to draw investment to fresh exploration in already expensive-to-drill offshore locations unless soaring costs, exacerbated by the country's regulatory regime, are reined in. National oil company Sonangol controls the award of contracts, which some critics say means the most-qualified firms are not always selected.

Total E&P Angola said that without major cost reductions, investment could stop unless oil prices were above USD 60/barrel. Angola oil output is expected to rise to 1.8 million barrels/day at the end of the year from 1.75 million barrels/day in December 2015.

Ghana's output, 100,000 barrels/day at the end of 2015, came almost entirely from the Tullow Oil-operated offshore Jubilee field. But production from the Twenboa, Enyenra, and Ntomme (Ten) project is set to come on stream around mid-2016, adding some 80,000 barrels/day when it peaks. In total, Ghanaian output should be changed at 102,000 by mid-year 2016 but rise to 125,000 barrels/day by year-end.

Production from Gabon's and the Republic of Congo's maturing fields has declined recently. It is expected that Congolese output will rise to about 315,000 barrels/day at the end of 2016 (Table 5).

West Europe

Hydrocarbon output from the UK Continental Shelf (UKCS) in 2015 managed its first increase for more than 15

Table 5. West African output (million barrels/day)

Country	End-2016
Nigeria	1.900
Angola	1.800
Republic of Congo	0.315
Equatorial Guinea	0.270
Gabon	0.270
Ghana	0.125
Total	4.680

Sources: Petroleum Economist

years, as spending on new-field development converted reserves into produced barrels. In 2016, oil production weakens slightly, as a result of natural declines in productivity, some field closures and a slow-down in new-field start-ups. UK output at the end-2016 will be of 0.914 million barrels/day. Gas production, meanwhile, may actually rise, with flows from Total's 0.5 billion cubic feet/day Laggan Tormore gasfield starting in the 1st quarter 2016.

The situation in Norway is similar. Oil output amounted to 1.57 million barrels/day in 2016. That constituted a 3% rise from 1.51 million barrels/day in 2015, as the pace of drilling and output from existing operations exceeded expectations. But although several significant discoveries are in development, a slow-down in infill drilling in response to weak oil prices is likely to push output back to around the 2015 level by the middle of the year, stabilising at that level over the full year. The Norwegian Petroleum Directorate forecasts average oil production of 1.53 million barrels/day in 2016.

World oil news

Turkey and Russia signed an agreement on 10 October 2016 for the construction of a major undersea gas pipeline. The pipeline is named TurkStream and will allow Moscow to strengthen its position in the European gas market and cut energy supplies via Ukraine, the main route for Russian energy into Europe. Russian President Vladimir Putin had agreed a gas price discount mechanism for Turkey as part of a broader deal to construct the TurkStream gas pipeline.

OPEC producers have their sights set on a sustained oil price of USD 50 - 60/barrel, a modest ambition for the first cut in supply by the oil exporting group in eight years, says one of the industry's top forecasters. Benchmark US oil prices have risen around USD 4/barrel, or around 9%, to over USD 48/barrel since the OPEC agreed at the end of September to shave output. The deal marks the return to supply caps for the producer group after a brutal two-year free-for-all when OPEC members ditched output targets and pumped more than the market needed in a price war that bloodied US oil shale producers. US oil output fell to around 8.7 million barrels/day in July 2016, the lowest since May 2014 and down over 730,000 barrels/day on the year, mostly as oil shale producers hit by low oil prices cut output.

India's ONGC Videsh Ltd. has signed definitive agreements with OJSC Rosneft to acquire an additional 11% interest in CJSC Vankorneft and therefore interest in Vankor oil and gas condensate field in East Siberia. The acquisition is expected to close by December 2016. If this transaction is completed, the Indian interest proportion in Vankor would rise to 49,9%. Vankorneft was established in 2004 for development of Vankor field in the Turukhansky district of Krasnoyarsk Territory. In 2015, Vankor produced 22 million tons of oil and 8.71 billion m³ (bcm) of gas according to Rosneft information.

Hindustan Oil Exploration Co. (HOEC) has advanced development of Dirok natural gas field in the Assam-Arakan basin, India, by letting a USD 30 million contract to Expro for a Modular Gas Processing Plant. Under a lease-operate-maintain agreement, Expro will provide the design, engineering, construction, transportation, installation and commissioning of the plant to be able to process up to 35 million standard cubic feet per day (MMscfd) of wet gas. In addition to the gas plant, development will include a gas gathering station and pipelines connecting those facilities and the field with partner Oil Industry Ltd.'s facilities at Kusijan.

State-owned Brahmaputra Cracker & Polymer Ltd. will buy the gas for transport to its Assam Gas Cracker complex at Lepatkaka via an existing pipeline. HOEC, operator, holds 26.882% interest in the license for Block AAP-ON-94/1. OIL holds 44.086% and Indian Oil Corp. Ltd. holds the remainder.

EOG Resources Inc., Houston, has agreed to combine with Yates Petroleum Corp., Abo Petroleum Corp., MYCO Industries Inc., and certain other entities. Under the terms of the deal, EOG will issue 26.06 million shares of common stock valued at USD 2.3 billion and pay USD 37 million in cash. EOG also will assume and repay at closing USD 245 million of Yates debt offset by USD 131 million of anticipated cash from Yates.

Yates is a privately held, independent crude oil and natural gas company with 1.6 million net acres across the western US, with production of 29,600 barrel of oil equivalent per day (Boed) net, of which 48% is crude oil and proved developed reserves of 44 million barrels of oil equivalent (MMboe). EOG says the deal adds an estimated 1,740 net premium drilling locations in the Delaware and Powder River basins, representing a 40% increase. The firm defines a premium drilling location as a direct aftertax rate of return of at least 30%

assuming a USD 40/barrel flat crude oil price. EOG plans to commence drilling on the Yates acreage in late 2016 with additional rigs in 2017.

Anadarko Petroleum Corp., Houston, has agreed to acquire the deepwater Gulf of Mexico assets belonging to Freeport McMoRan Oil&gas (FMOG), a subsidiary of Phoenix-based mining firm Freeport-McMoRan Inc., for USD 2 billion. The deal will double Anadarko's ownership in its operated Lucius deepwater development to 49% and add 80,000Boed, 80% of which is oil, to the firm's sales-volume guidance. The acquisition comes as Anadarko lifts Lucius field's estimated ultimate recovery to more than 400MMboe from the previous 300MMboe given "strong reservoir performance and facility productivity."

Gross oil sales volumes through the Lucius facility recently surpassed 100,000 barrels/day. Accounting for the newly acquired assets, Anadarko's gulf position will have net sales volumes of 155,000Boed, 85% of which will be oil.

Lucius field lies on Keathley Canyon Blocks 874, 875, 918, and 919 about 240miles south of Louisiana's coast in 7,100ft of water. Production from the facility began in early 2015. Anadarko expects these acquired assets to generate substantial free cash flow, enhancing its ability to increase US onshore activity in the Delaware and DJ basins. Excluding the acquired assets, Anadarko is expected to increase its full-year capital guidance to USD 2.8 - 3 billion, primarily reflecting the increased activity in those onshore basins. Al Walker, Anadarko chairman, expects the rise in activity over that time period to result in a companywide 10 - 12% compounded annual growth rate in oil volumes in a USD 50 - 60/barrel oil-price environment.

Petrobras has set its planned spending for 2017 - 2021 period to USD 74 billion, down 25% from its 2015 - 2019 plan. The Brazilian state-owned firm said it hopes to divest USD 19.5 billion in assets over the next couple of years, pledging to exit biofuel production, LPG distribution, fertilizer production, and investments in petrochemicals. Petrobras has maintained a divestment target of USD 15.1 billion for 2015 - 2016.

Additional costs savings are expected through increasing strategic partnerships in exploration and production, refining, transportation, logistics, distribution, and sales.



The moves are part of an effort to cut the firm's USD 125 billion debt load. The financial target determines that the company's net debt be equivalent to 2.5 times its cash generation in 2018. According to Petrobras' 2015 annual balance sheet, this index reached 5.3 times.

Most of the investment under the new 5-year plan, 82%, will be directed toward exploration and production activities, 17% to refining and natural gas, and the remaining 1% to other areas.

Petrobras is targeting 2.8 million barrels/day in oil and natural gas liquids production by 2021, sustained by operating performance and the application of new technologies. The firm notes the average time to build an offshore well in the Santos basin presalt cluster has been cut to 54 days in 2016 from 152 days in 2010.

In the next couple years, Petrobras will concentrate on recovering its financial strength as an integrated energy company that is focused on oil and gas.

Partners in the Levithan natural gas project offshore Israel have signed an agreement to supply as much as 45 billion m³ of gas to a Jordanian power company. NBL Jordan Marketing Ltd., a wholly owned subsidiary of the Levithan partners, will supply the gas at the Jordan-Israel border to National Electric Power Co. of Jordan. The agreement is for 15 years unless shipments reach the maximum volume earlier. Total revenues under the agreement are estimated at USD 10 billion.

Shareholders of Singapore-based InterOil Corp have overwhelmingly voted to approve ExxonMobil Corp's USD 2.5 billion bid for the company at a special meeting



Sources: energyvoice.com

on 19 September 2016. The deal will deliver shareholders a material and immediate premium, a potential direct cash payment based on the Elk-Antelope gas-condensate field resource certification in Papua New Guinea, and exposure to future value through ownership of ExxonMobil shares. InterOil's major asset is Elk-Antelope field in the eastern highlands of Papua New Guinea along with surrounding exploration permits covering about 16,000km². The gas resources are the potential feedstock for the proposed Papua LNG project, which is operated by Total and its fellow joint venture Oil Search Ltd. in appraising and planning the development



Figure 1. Crude oil price movement from January to October 2016

that calls for a pipeline from the fields to an LNG plant at Caution Bay about 2km from Port Moresby.

Petronas has let contracts for industrial gas and power supplies and equipment for long-planned Pengerang integrated complex (PIC) and refinery and petrochemical integrated development (RAPID) project at Pengerang in southeastern Johor, Malaysia. As part of long-term supply agreements with Petronas, Pengerang Gas Solution Sdn. Bhd. (PGS) - a joint venture of Linde AG subsidiary Linde Malaysia Sdn. Bhd. and Petronas Gas Bhd. (PGB) - will invest Euro 150 million to build a grassroots air gas plant that will produce gaseous oxygen and nitrogen to meet RAPID's industrial gas needs, according to Linde. The air gas plant, which will include two large air-separation units (ASU) and associated gas installations, will be built on site at the PIC complex and be equipped with proprietary air-separation technology from Linde, which will also provide engineering, procurement, construction, and commissioning services for the ASUs as part of a separate contract with PGS. Linder disclosed no further details regarding the value or specific duration of the supply agreements.

Oil market

According to World Bank's latest Commodity Markets Outlook released on 20 October 2016, while world oil demand is projected to increase in 2016, there has been a marked slowdown in its pace of growth. Demand expanded by 1.5 million barrels/day (1.6%) year-on-year in the 1st quarter, but only 1.3 million barrels/day (1.4%) in the 2nd quarter (Figure 2). The slowdown occurred in both OECD and non-OECD regions. Demand growth is estimated to have slowed further to 0.8 million barrels/day (0.8%) in the 3rd quarter, with all of the reduction in the OECD. Non-OECD oil demand growth began rising 1.4 million barrels/day, or 3.0%, in the 1st quarter 2016, but slowed to around 0.9 million barrels/day in the 2nd quarter, and the 3rd quarter. Much of the recent weakness was in East Asia, with China recording little growth in the 3rd quarter due to slowing industrial use and other temporary factors, such as heavy flooding that impeded transportation. India's

demand remained robust, rising 0.3 million barrels/day, or 8%, year-to-date. World oil demand for 2016 is projected to increase by 1.2 million barrels/day (1.3%) to an average of 96.3 million barrels/day. OECD oil demand is projected to rise by 0.1 million barrels/day, with increases in Europe offsetting declines elsewhere. Non-OECD oil demand is projected to rise

by 1.1 million barrels/day (2.3%), led by increases in China and India but at the slowest pace since 2009. In 2017, global demand growth is expected to rise by 1.2 million barrels/day (1.3%), with most of the growth projected outside the OECD, and a small increase in North America.

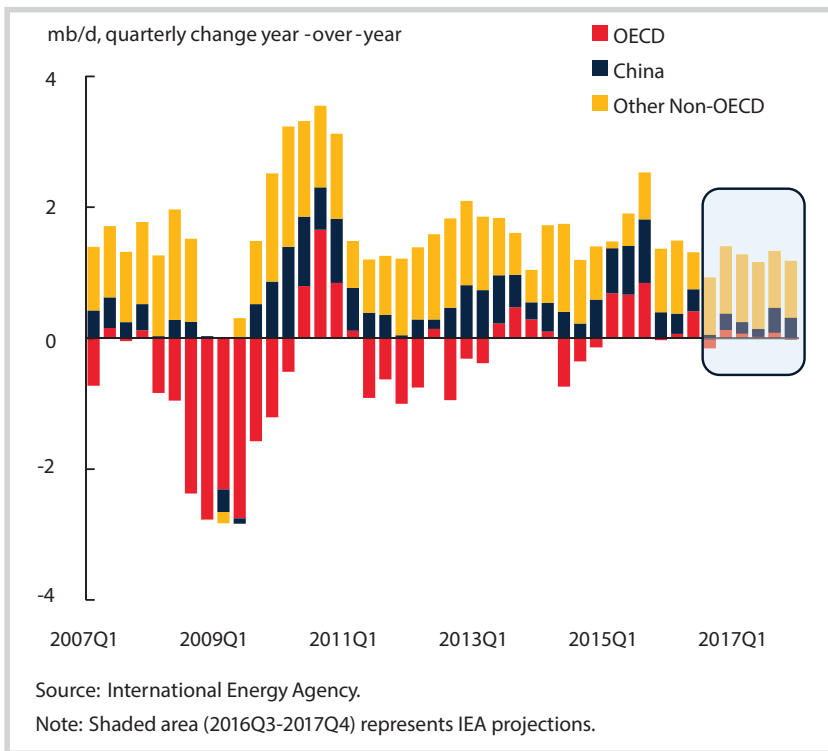

Figure 2. World oil demand growth

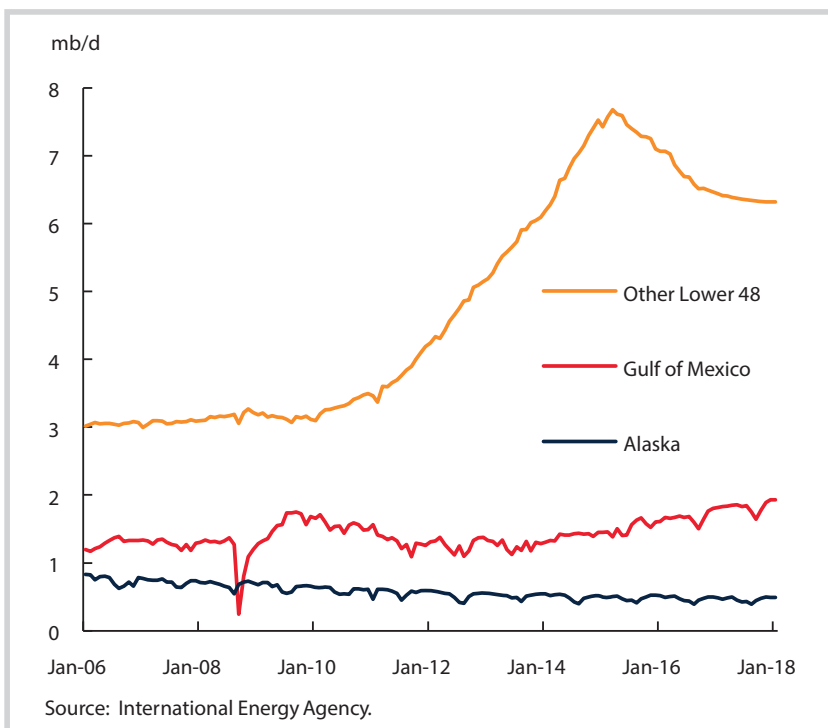

Figure 3. US crude oil production

Global oil production and consumption were broadly matched in the 2nd quarter, and the 3rd quarter 2016, compared with large surplus production of 1.2 million barrels/day in the 1st quarter 2016, and 1.6 million barrels/day in 2015. Supply outages in the 2nd quarter and continued declines in non-OPEC supply, notably in the United States, constrained production. In the 3rd quarter 2016, world oil supply was slightly lower compared with a year earlier, with declines in non-OPEC output nearly offset by increases in OPEC production, led by the Islamic Republic of Iran and Saudi Arabia, and biofuels. Non-OPEC supply peaked in the 4th quarter 2015 and began falling year-on-year in the 1st quarter 2016, as the large investment cutbacks over the past two years began to curtail production. Output fell by around 1.2 million barrels/day (2%) in the 2nd quarter and the 3rd quarter, with most of the decline concentrated in the United States and, to a lesser extent, China. There were also notable decreases in Canada (due to spring fires in northern Alberta), Colombia, Mexico, and South Sudan (due to outages). These were partly offset by gains in Brazil, Republic of Congo, and the Russian Federation. Non-OPEC supply is expected to fall a further 1.2 million barrels/day in the 4th quarter 2016, and record a decline of 0.9 million barrels/day (2%) for 2016 as a whole, with nearly three-quarters of the decrease accounted for by production cuts in North America. For 2017, non-OPEC supply is projected to increase year-on-year beginning in the 2nd quarter, for an annual rise of 0.4 million

barrels/day. Notable gains are expected in Brazil, Canada and Kazakhstan, with small increases in Ghana, Republic of Congo, Russian Federation and other countries as past investments undertaken prior to the oil price collapse come on stream. Declines are expected mainly in China, Mexico, the North Sea, and the United States where higher-cost producers are cutting back production. US oil production, which peaked at 9.7 million barrels/day in April 2015, fell to an estimated 8.4 million barrels/day in September 2016. Virtually all of the 1.3 million barrels/day decline over this period was in the on-shore lower 48 US states, shale-oil production takes place, with output in Texas falling 0.5 million barrels/day. A small decline in Alaska was more than offset by a 0.1 million barrels/day rise in the Gulf of Mexico. US drilling activity has increased by over one-third since May after having plunged 80% from its peak in October 2014. Despite the increase of rigs drilling for oil to 432 between May and October 2016, the number of oil rigs in operations remains one-quarter of its October 2014 high of 1,609 rigs (Figure 4). As a result, production from the main shale basins fell nearly 1 million barrels/day, according to the EIA. The largest drops were high-cost production sites in Eagle Ford (Texas 0.6 million barrels/day), Bakken (North Dakota 0.3 million barrels/day), and Niobrara (Colorado/Nebraska 0.1 million barrels/day). An exception is the Permian basin in Texas, where shale oil deposits are among the lowest-cost to access and where drilling has recovered as global oil prices stabilised. Large productivity improvements in the shale industry have supported production. Productivity in the Eagle Ford and Bakken basins has risen from less than 300 barrels per well in early 2012 to more than 1,100 and 800 barrels, respectively. In the

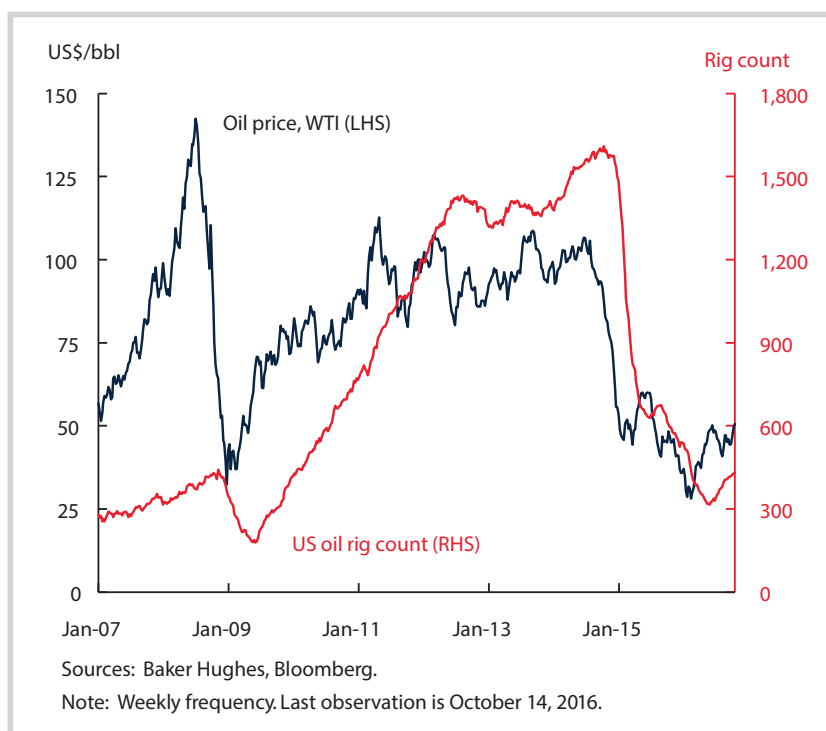

Figure 4. US oil rig count and oil prices

Permian basin, productivity improved five-fold from 100 barrels per well to more than 500. The industry is also reducing its backlog of drilled but uncompleted wells (DUC), from which oil can be extracted at roughly two-thirds the cost of a new well. OPEC crude oil production averaged 33.5Mbd in the 3rd quarter 2016, up 0.5 million barrels/day from the 2nd quarter, and more than 0.8 million barrels/day higher than the 3rd quarter 2015. Since the end of 2015, OPEC Gulf production rose by 1.0 million barrels/day with increases centered in the Islamic Republic of Iran and Saudi Arabia (Figure 5). Iranian output is up nearly 0.8 million barrels/day to 3.7 million barrels/day, with exports of around 2 million barrels/day, compared with pre-sanctions exports of 2.2 million barrels/day. Meanwhile non-Gulf output dropped by 0.6 million barrels/day with declines in Nigeria (due to pipeline attacks), and the República Bolivariana de Venezuela (due to financial and operational difficulties). In Libya, the reopening of ports helped lift production from under 0.3 million barrels/day in August to 0.5 million barrels/day in October. The national oil company is aiming for output of 0.9 million barrels/day by the end of 2016. Nigeria's production is also poised to increase if a ceasefire agreement with rebel groups holds. In late September, OPEC members agreed to limit output to 32.5 - 33 million barrels/day, effectively ending two years of a market share strategy and unrestrained production. This represents an important policy shift for Saudi Arabia, its largest producer. The committee is also tasked with preparing a framework for consultations with non-OPEC producers. Russia has signaled support for OPEC's decision to limit production, with the possibility of reducing output. The Islamic Republic of Iran, Libya and Nigeria will likely be granted special exemption because of earlier production losses. If implemented, it will be the first production cut since 2008. There remain important pending decisions

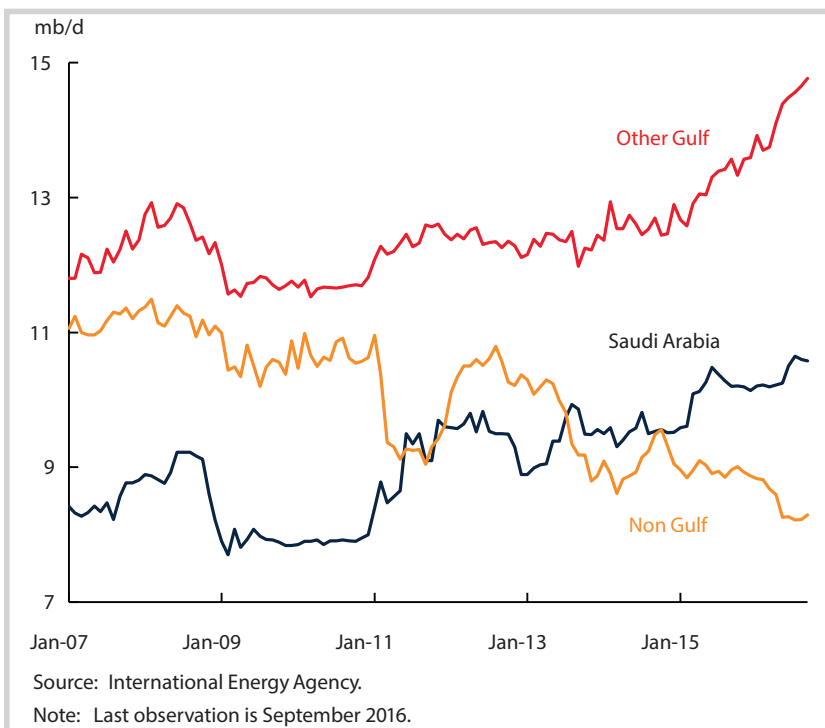

Figure 5. OPEC crude oil production

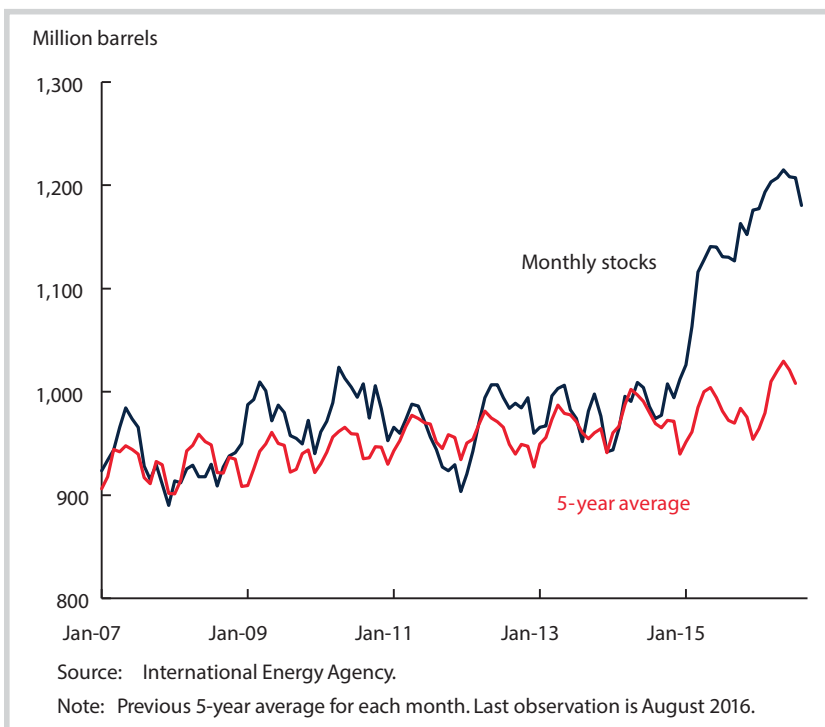

Figure 6. OECD crude oil stocks

about individual quotas, the timing of implementation, and the level at which the Islamic Republic of Iran might freeze production. A cut to 32.5 million barrels/day would entail a 1.0 million barrels/day reduction from current output, and 0.5 million barrels/day if the overall ceiling was 33 million barrels/day. Part of the near-term reduction would occur in any event, as Saudi Arabia usually reduces winter production by some 0.4 million barrels/day due to lower power generation requirements. Should the Islamic Republic of Iran, Libya, and Nigeria raise production significantly in the next few months, cuts by other producers will need to be even larger to meet their overall targets.

Therefore, World Bank have raised its forecast for crude oil prices to average USD 43/barrel in 2016, a decline of 15% from 2015, and average USD 55/barrel in 2017. Consumption is expected to begin to exceed production in 2017, particularly in the second half of the year, and help reduce the large inventories. The forecast assumes OPEC will succeed in limiting global production, and that US production will flatten out in 2017. There are significant risks to the forecast, especially given uncertainties about the implementation of OPEC's agreement and the trajectory of inventories. Upside risks include a larger-than-expected OPEC cut, and further outages in some oil exporters (e.g., Libya, Nigeria, República Bolivariana de Venezuela). Downside risks to prices center on weak demand, earlier-than-expected return of lost production, and failure of OPEC to implement a meaningful reduction in output.

Collected by Tran Ngoc Toan